



**HUMIDITY MANAGEMENT MODULE  
TYPES H22 *Digital*  
and H222 *Digital***

**USER INSTRUCTIONS**

Contents

<u>Section</u>	<u>Subject</u>	<u>Page</u>
1	Introduction	2
2	Unpacking	2
3	Installation	3
4	Operation	6
5	Routine Maintenance	7
6	Troubleshooting	7
7	Specifications	8

## 1.0 INTRODUCTION

These instructions detail the installation and operation of your new H22 or H222 *Digital* Automatic Humidity Management Control Module. Please read them carefully before setting up your machine to achieve best results and keep these instructions safe for future reference. The H22 and H222 offer convenient and refined measurement and control of incubation humidity.

The H22 is specifically designed to compliment Brinsea Octagon 20 and 40 incubators but can be used with any forced draught (fan assisted) incubator of capacity up to 1,000 hens eggs approx. The high capacity H222 version is identical to the H22 except that the pumping capacity is much greater making it suitable for incubators of between 500 and 10,000 hen eggs capacity (approximately). The installation of both types is similar although the H222 is not compatible with the Octagon 20 or other small incubators. For convenience the following instructions referring to the H22 also apply to the H222. Any differences are noted in the text.

### FEATURES

- Continuous, permanent metering of relative humidity (%RH)
- Proportional control easily set against scale
- Sensor unit with high accuracy bulk polymer sensor
- Pumped water flow - not level dependent

### PRINCIPLE OF OPERATION

The sophisticated bulk polymer sensor provides a highly accurate, linear signal of the relative humidity level within the incubator back to the Humidity Module which then displays this % Relative Humidity (RH) level on the large digital display.

The control system operates a tiny in-built water pump which transfers exactly the amount of water required into the incubator to maintain the required relative humidity which is set by the user. The control system compensates for changes in relative humidity level and, within working limits, will maintain a constant relative humidity level.

Note for users of earlier H22 (non-digital) models that the sensors in the earlier models are not interchangeable with *Digital* units.

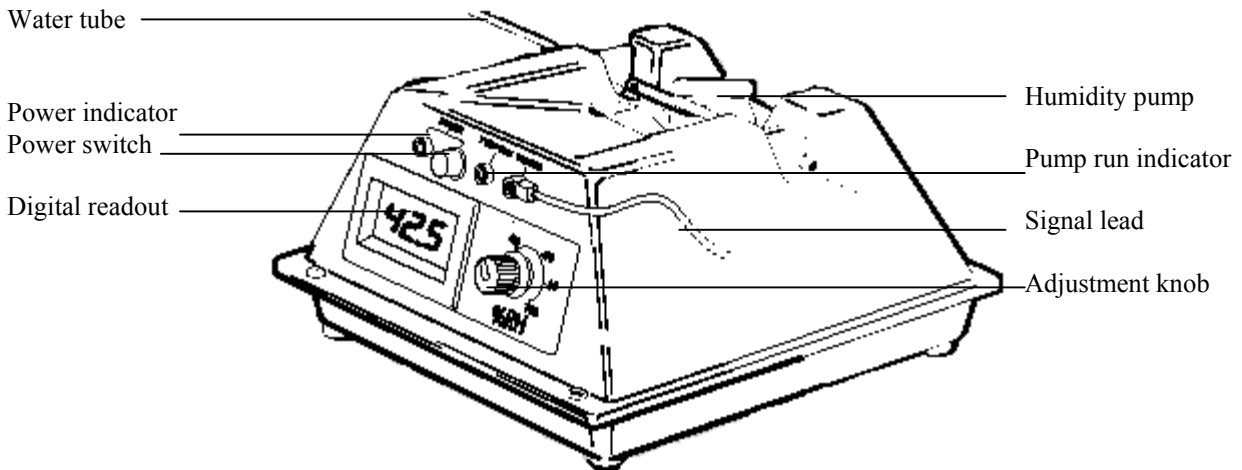

## 2.0 UNPACKING

The H22 *Digital* (or H222 *Digital*) comprise:

- 1 Type H22 *Digital* (or H222 *Digital*) humidity module control unit**  
Free standing unit for mains electrical supply containing control and indication functions and pump.
- 1 Sensor unit**  
Fits inside the incubator or through the incubator wall. Contains the (removable) sensor, signal lead socket and mounting clip.
- 1 Water tube (8 feet)**  
Silicone rubber tube for interconnecting and for peristaltic pump replacement.
- 1 Signal lead**  
Flex with jack plugs for connecting between control unit and sensor unit.
- 2 Sheets Evaporating pad (letter size approx.)**  
To be cut to suit incubator type.  
(Note: A bulk water reservoir is not supplied. Any plastic or glass food container may be suitable.)
  - 2.1 Remove all tape and packing from the module and parts. Retain the carton and packing materials to enable the unit to be repacked. Please take care not to discard the pack of heavy white evaporating pad paper. Note also that the black sensor fits into a socket in the sensor unit and can be pulled to remove. Take care not to lose the sensor, replacements are expensive.
  - 2.2 Identify each part and check that they are all present and undamaged. If there are any parts damaged or missing please contact your dealer or Brinsea Products (at the address at the end of the document).
  - 2.3 Check also that the electrical supply matches the machine's requirements (marked on the technical label on the base of the module).
  - 2.4 Complete and return your guarantee card to register for the free two year guarantee covering your incubator.
  - 2.5 Go to [www.Brinsea.com](http://www.Brinsea.com) and register as a free member of the Brinsea e-mail group to receive the latest news and information such as advance notice about new products, special offers, exclusive competitions and much more.

## 3.0 INSTALLATION for Octagon 20 MkIII or Digital and Octagon 40 Digital

### Mounting the sensor unit

- 3.1 Remove the black blanking plate from the side of your Octagon 20 incubator by pushing out plastic rivets from the inside of the incubator with a screw driver. (Fig. 1)
- 3.2 Use the screws provided to attach the black sensor clip to the outside of the incubator. Use the screw holes from the black plate that you previously removed. Making sure that the grooved edge fits snugly into the hole on the side of the incubator. The clip should face out and the long flat side should face downwards. (Fig.1).

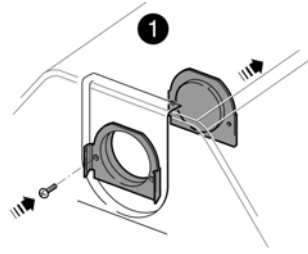
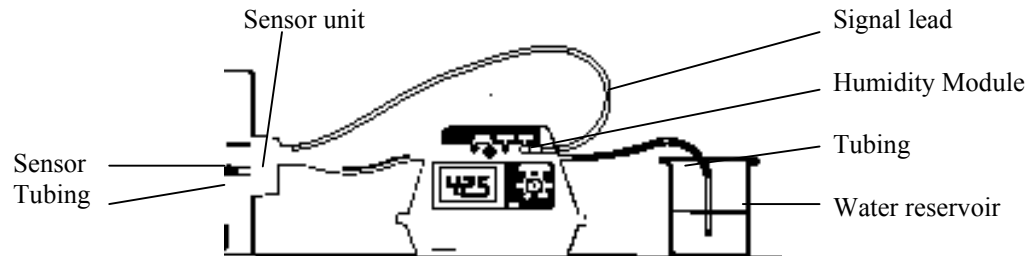
Fig. 1**Connecting Up**Fig. 2

- 3.3 Push a 3 inch (75mm) length of the silicone tube to the nipple on the sensor unit adjacent to the black sensor (moistening the end of the tube helps). Ensure the small black rectangular sensor is firmly pushed into its socket in the sensor unit. If it should come out, ensure it is replaced the right way up with the three pins closer to the top. If inserted upside down, the sensor will give an incorrect negative reading. Push the whole sensor unit into the black mounting clip on the end of the clear incubator lid adjacent to the mains power cable, until it locates with a 'click'.
- 3.4 Cut a second length of silicone tube long enough to reach easily from the sensor unit to the Humidity Management Module and push one end onto the nipple on the outside of the sensor unit. The other end of this length is pushed onto the output (left side) of the Humidity Management Module (the label on the module shows the direction of water flow with an arrow).
- 3.5 The H22 Humidity Management Module is supplied with a length of silicone tube fitted around the pump rotor. This length will wear and need periodic replacement. It can also become flattened if left unused for some time because the inside walls of the tube will stick to each other around the rotor and prevent water passing through. This can happen from new if the unit has been stored for a time. Either replace this length of tube (see section 13) or remove it and roll it between finger and thumb to 'unstick' it.
- 3.6 Connect a last length of tube between the input to the pump (right side) and a water reservoir. A gallon of distilled water works well.
- 3.7 Plug one end of the sensor signal lead into the socket in the sensor unit and the other end into the socket in the Humidity Management Module.
- 3.8 Ensure that neither the tube nor signal lead can impede the rotation of the incubator.

**3.10 Fitting the evaporating pad (see Fig.3)**

Cut a piece of evaporating pad 8.5" x 2.5", scored and folded longways. The evaporating pad is suspended in a "V" arrangement, located in the slot on the underside of the fan guard. The pad is retained by two plastic clips which are pushed onto the two lugs on either end of the slot in the fan guard. The tube from the sensor unit is then laid in the centre of the "V".

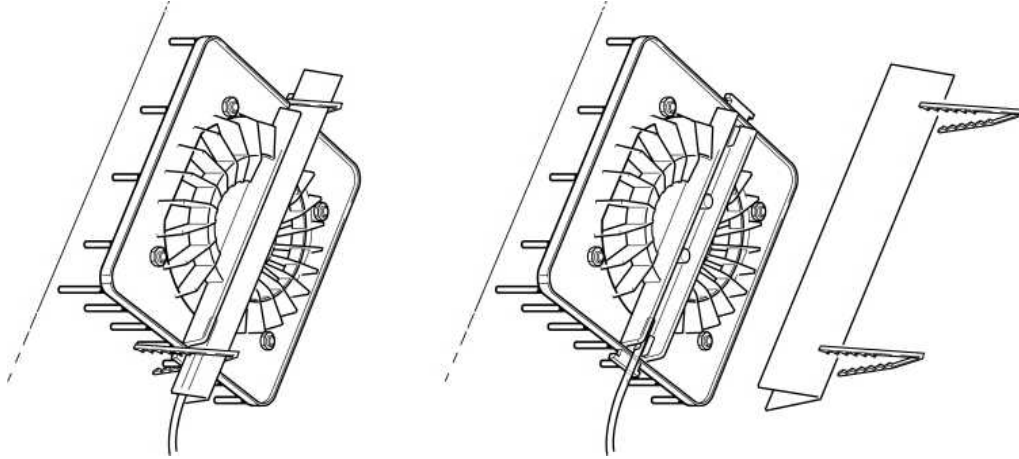
Fig 3.

## INSTALLATION for other incubators

### 3.11 Mounting the sensor unit

The sensor unit can either be mounted inside the incubator or through the incubator wall.

3.12 The sensor must be in a representative place in the incubator, with air movement over it.

### 3.13 Wall mounting for thin walled incubators

For incubators with walls less than 1/8" (3mm) thick the mounting clip can be fixed directly on the outside of the incubator. Choose a place where the clearance inside is at least 1.2" (30mm) to leave room for the sensor. Cut a 1" diameter hole using a Q-max punch or hole saw. Locate the circular flange on the clip in the hole the correct way up as shown above.

3.14 Mark the two 1/8" mounting screw holes. Drill the two holes and fix the clip with the countersink screws provided to the outside of the cabinet. Be sure the fit is good. If necessary, use silicone sealant to bed the clip.

### 3.15 Wall mounting for thick walled incubators

If the incubator wall is thicker than 1/8" (3mm), follow the procedure for thin walled incubators but mount to a thin plastic panel (available as an option) fixed on the inside of the incubator wall. It will be necessary to cut a hole about 2 1/2" diameter through the thick wall to pass the complete sensor unit through.

This procedure is necessary to ensure that the sensor is well into the incubator air stream.

### 3.16 Mounting inside incubator

The sensor unit can be mounted completely inside the incubator by making a suitable bracket drilled as described above. Provision must be made to seal around the flex and the water tube where they pass through the incubator cabinet wall. Bracket design will depend upon the incubator.

### 3.17 Fitting the evaporating pad

Most incubators are provided with water pans for humidification - usually in the base. This would be the obvious place to put the pads. The pad area needs to be as large as possible, certainly as large as the area provided for water (see humidity and ventilation). A short length of rubber tube should be cut to link between the sensor unit outlet and the evaporating pad.

Caution: Be sure to arrange the pad and the tube so that water will not spill onto electrical equipment even if the pump overruns.

### 3.18 Connecting up

Place the control unit alongside the incubator as near as possible to the sensor unit. Place your water reservoir below or adjacent to the sensor unit (not above or water may siphon when changing pump tubes). Keep tube connections as short as possible. Connect tubes as shown below.

Use the flex provided to connect the socket on the sensor unit to the socket on the control unit. Connect the control unit to the mains supply.

## 4.0 OPERATION

The module will be factory calibrated but may be returned to the address below for re-calibration if necessary.

- 4.1 Fill a suitable container with water and place the pump inlet tube into the container ensuring the tube is below the water level.
- 4.2 Press the power supply switch . Power indicator will light. Turn the humidity control knob anti-clockwise to minimum.
- 4.3 The meter will give a readout of humidity, at incubation temperature this will usually be a fairly low figure (15 to 30%). Allow 5 minutes for the reading to stabilize and adjust the humidity control knob to raise the humidity, the pump will run and the 'pump run' indicator will light. To achieve the desired relative humidity level allow 30minutes between adjustments and use the meter reading as your guide to turning the control knob up or down.
- 4.4 When the humidity level is stable the pump will cut in and out evenly, pumping small amounts of water to offset moisture losses as incubator air is passed out through ventilation holes.
- 4.5 Guidelines for incubation humidity levels:

During incubation:	Poultry	40-50%
	Waterfowl	45-55%
	Ratites	20-35%
	Parrots	35-45%
	Most Birds of Prey (Thin shelled - Merlins, Kestrels, Owls	40-45% RH 50%RH)
Hatching	All species	65% RH or more

To determine the correct humidity level for any given species either consult available literature (a range of bird keeping and breeding books is available from Brinsea Products at the address below) or experiment with different humidity levels and record which proved most successful or weigh eggs during incubation. Eggs loose moisture through their shells and the rate of evaporation depends on the humidity levels around the eggs. During incubation eggs need to loose a fixed amount of water which corresponds to a loss in weight of around

13-16% depending on species. By weighing eggs periodically during incubation it is possible to monitor and, if necessary, correct humidity levels to achieve the correct weight loss.

Weigh the eggs on the day they are set in the incubator, take the average weight and plot this on a graph (see example below). The ideal weight loss line can be plotted by joining the point representing initial average weight with the ideal hatch weight (13-16% less depending on species) with the x-axis representing the incubation period (in days).

By measuring actual average weights every few days the actual weight loss can be plotted and compared to the ideal weight loss line and corrections can be made. For example if the actual weight loss was greater than ideal (see graph below) then the air has been too dry and humidity levels need to be increased to compensate.

Typical ideal weight losses for species groups:	Poultry	13%
	Waterfowl	14%
	Birds of prey	18%
	Ratites	15%
	Parrots	16%

**Egg weight loss chart**

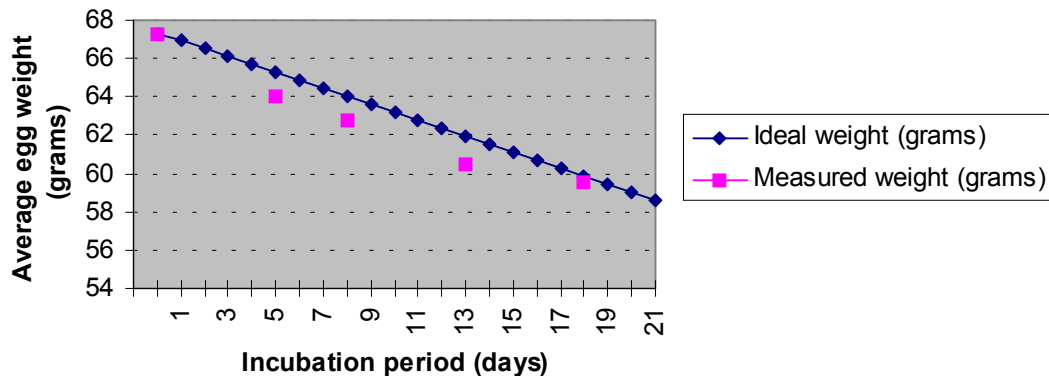

## 5.0 ROUTINE MAINTENANCE

### 5.1 Changing the pump tube

The peristaltic pump will need to have its tube replaced about every 3 months. Cut a length of tube to about 5¼". Remove the connectors and pull off the old tube. Replace with the new tube, avoiding twists. Use the diagram on the product label to thread the tube exactly as shown over the pump head. The tension must be sufficient to ensure complete occlusion of the tube without unnecessary flattening between the pump rollers. Adjust tube length as necessary. Ensure that the tube does not stick together if left for long periods by unhooking it during storage.

### 5.2 Changing the evaporating pad

Change the pad as necessary to maintain good evaporating efficiency. If chicks are to be hatched in the incubator, change the pad after each hatch to avoid bacterial contamination.

### 5.3 No lubrication or further servicing is required beyond the instructions above.

## 6.0 TROUBLESHOOTING

The control module is calibrated from 0 to 100% RH and is theoretically capable of controlling throughout most of the range. However, the minimum and maximum levels of humidity achievable in an incubator depend upon several factors, particularly the fresh air ventilation rate. You may need to allow 24 hours for humidity to stabilize after making changes.

If you cannot get the level of RH you want, consider these notes:

### 6.1 Humidity will not go low enough

First increase the fresh air ventilation level - enlarge ventilation holes in the incubator cabinet. This will help to dilute the moisture given up by the eggs. There will still remain a lower limit determined by the moisture content of the ambient air, particularly in warm humid conditions. This can only be countered by dehumidification of the room air outside the incubator with proprietary dehumidifier but is rarely a problem in practice except with ratites.

### 6.2 Humidity will not go high enough

Restrict fresh air ventilation to the minimum safe level. Remember embryos need to breathe! Increase evaporating pad area. If the pad is too small, you may have a flood in your incubator.

Do not attempt to achieve higher than 80% RH.

Check that water is reaching the incubator when the pump runs – if not check the whole length of the tubing for kinks and check that the tubing around the pump has not become permanently flattened. If it has, replace the pump tube. Silicone tubing is very flexible but can be damaged by sharp finger nails. A tiny perforation on the suction side of the pump will let in air and prevent the pump drawing water.

## 7.0 SPECIFICATIONS

Sensor:	Sensor accuracy +/- 3%. Hysteresis 0% R.H. Response time 2 minutes
Water Transfer:	In-built peristaltic pump Maximum water flow rate 1oz/hour (H22), 8oz/hour (H222)
Control setting and metering:	Indicated in % RH (linear)
Electrical supply:	220-240v 50Hz or 115v 60Hz as ordered
Power consumption:	12 Watts max.
Dimensions:	approx. 7 x 8 x 4 1/2" (W x D x H)
Weight:	2.2lbs

**Brinsea Products Inc., 704 N Dixie Ave., Titusville, FL 32796-2017 USA.  
Phone. (321) 267-7009 Toll Free 1-888-667-7009 Fax (321) 267-6090  
e-mail BrinseaUSA@aol.com, website www.Brinsea.com**