

Brinsea

Octagon 20 and 40 *Digital* high performance egg incubators

Users instructions

Contents

<u>Section</u>	<u>Subject</u>	<u>Page</u>
1	Introduction	2
2	Unpacking	2
3	Location and Installation	3
4	Storage of eggs	4
5	Temperature	4
6	Humidity and Ventilation	5
7	Egg setting	7
8	Egg turning	7
9	Hatching	7
10	Cleaning up	8
11	Servicing	8
12	Troubleshooting	9
13	Specifications	10

1.0 Introduction

These instructions detail the operation of your new Octagon 20 or Octagon 40 digital incubator and Autoturn cradle (if supplied). The Autoturn cradle is supplied with the Octagon 40 but is optional for the Octagon 20. Please read these instructions carefully before setting up your machine to achieve best results and keep these instructions safe for future reference. This document includes recommended procedures for successful hatching but incubation involves the control and manipulation of a large number of factors and in certain circumstances different procedures may be necessary. Your incubator is designed to allow the user to vary the incubation conditions to suit a wide range of species in different ambient conditions and the specific set-up for every situation is beyond the scope of these instructions.

There are a range of books available covering incubation techniques, for more information or to request a book list please don't hesitate to contact us.

These advanced incubators are available with a number of options (such as the Automatic Humidity and Temperature Alarm Modules) and in these cases separate operating instructions for these modules are supplied

Fig. 1 Functional features of the Octagon 20 and Autoturn cradle (Octagon 40 functionally similar).

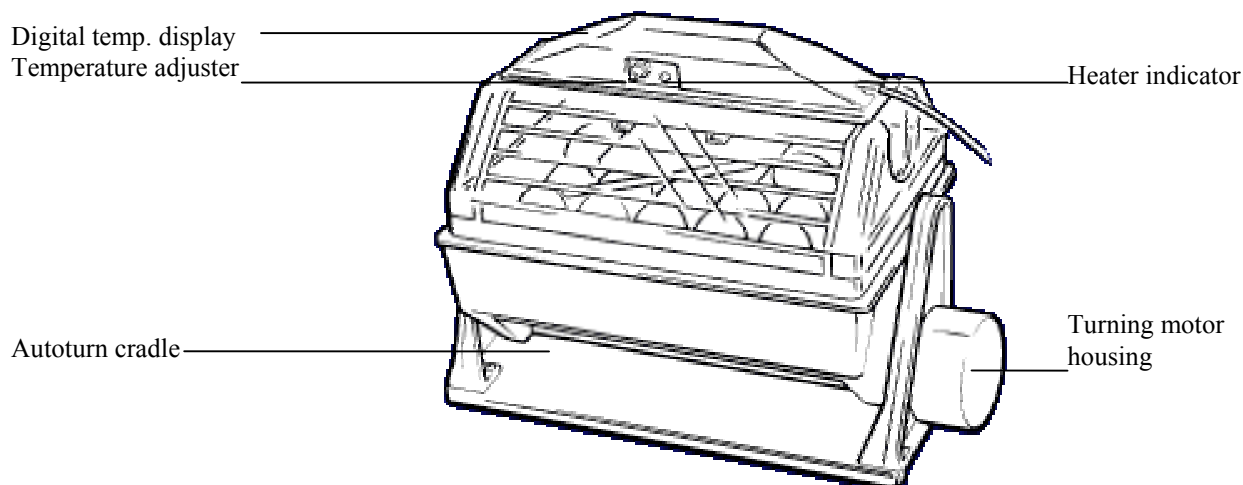

2.0 Unpacking

Your incubator has been supplied in protective packaging. Please remove all tape, strapping and packing from the incubator and parts. Retain the carton and packing materials to enable the unit to be repacked.

Your Octagon 20 will include as standard:

<u>Quantity</u>	<u>Item</u>
1	Incubator (including removable top)
1	Egg basket (black)
1	Set of six egg dividers
1	Guarantee Card

Your optional autoturn cradle will include as standard:

<u>Quantity</u>	<u>Item</u>
2	Base bars
1	Motorized cradle end
1	Plain cradle end
1	Set of four bolts
1	Diagram showing the assembly of the autoturn cradle.

Your Octagon 40 will include as standard:	<u>Quantity</u>	<u>Item</u>
	1	Incubator (including removable top)
	1	Egg basket (black)
	1	Set of six egg dividers
	1	Guarantee Card
	2	Base bars
	1	Motorised cradle end
	1	Plain cradle end
	1	Set of four bolts

- 2.1 Please identify each part and check that they are all present and undamaged. If there are any parts damaged or missing please contact your retailer or Brinsea Products (at the address at the end of the document)
- 2.2 Note that if your incubator has been ordered with additional options (such as the Automatic Humidity Module or Temperature Alarm Module) separate instructions and component lists apply.
- 2.3 Check also that the electrical supply matches the machine's requirements (marked on the technical label on the inside of the lid of the incubator and on the inside of the blank autoturn cradle end). UK machines are fitted with 3 Amp mains plug fuses – if replaced always use this rating.
- 2.4 Complete and return your guarantee card to register for the free two year guarantee covering your incubator.

3.0 Location and Installation

Your incubator will give best results in a room free from wide temperature variations and with generous ventilation – particularly if several incubators are running at the same time. Ensure that the room temperature cannot drop on a cold night. Ideally thermostatically control the room at between 20 and 25°C (68 and 77°F). Never allow the room temperature to drop below 15°C (59°F) and ensure that the incubator cannot be exposed to direct sunlight.

- 3.1 If using the autoturn cradle: Assemble the autoturn cradle in accordance with the diagram below (fig. 2) and place on a flat, level surface (workbench height is ideal). Place the incubator into the autoturn cradle as illustrated (fig. 1). The cabinet is designed to locate onto the lugs at either end of the autoturn cradle. Ensure that these are fully engaged in the slots in the ends of the incubator so that the incubator is level.

Fig.2

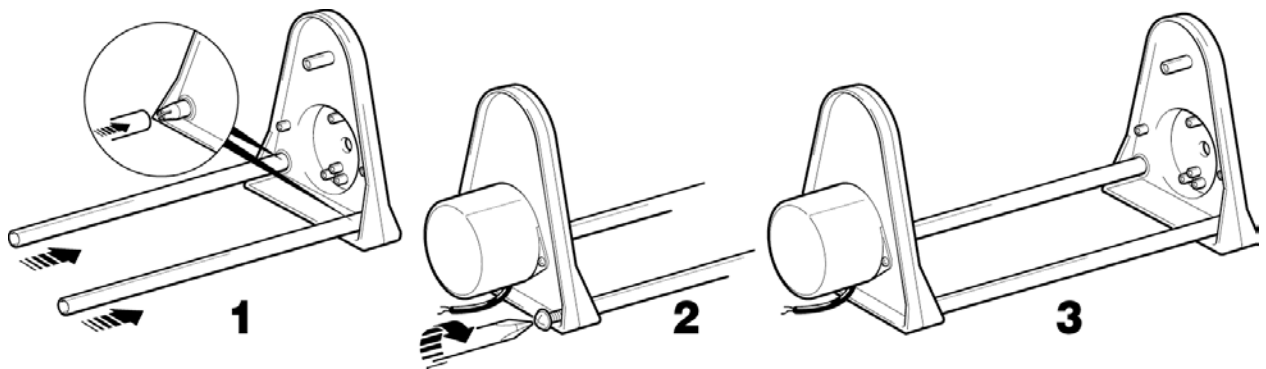

- 3.2 If using without the autoturn cradle place the incubator upright on a flat level surface.
- 3.3 Remove the lid, lift out the egg basket(s) and fill one of the two water channels with water (two of the four for the Octagon 40) leaving the top of the water 20mm (3/4") from the top of the channel. Replace the basket(s) and replace the lid. Ensure that the lip of the lid locates in the groove on the matching part of the base (Octagon 40 only). Slide the ventilation control to the centre of its range.

- 3.4 Plug incubator (and cradle if supplied) mains supply cable into a suitable outlet ensuring that the cable is not pulled tight. The incubator fan(s) will start, the red LED on the temperature control housing will illuminate continuously and the digital temperature display will show the air temperature. The cradle motor will start and the incubator will begin to turn. The turning is very slow – taking about half an hour to turn each way.
- 3.5 Allow the incubator to run for at least an hour to stabilise the temperature before making adjustments or setting eggs (see section 5.0 below).

4.0 Storage of eggs

- 4.1 Store eggs in cool, damp conditions. Most species may be safely stored for up to 14 days before serious reductions in hatch rates are likely. Daily turning of stored eggs also helps maintain hatchability.
- 4.2 Discard cracked, mis-shaped and heavily soiled eggs (if possible). Only wash soiled eggs using a proprietary egg wash solution following the manufacturer’s instructions. It is essential to wash eggs in solution which is significantly warmer than the egg. Bear in mind that all solutions will remove the outer cuticle from the egg as well as the dirt and may leave the egg at greater risk from bacterial contamination in the future.

5.0 Temperature

Stable and correct temperature is essential for good results. Adjust with care.

Note: your incubator may not be set to the correct temperature from the factory and the following procedure must be followed before setting eggs.

- 5.1 As the incubator warms up and approaches its control setting the red LED will change from continuously on to flashing. Allow the incubator to stabilise for at least an hour before adjusting the temperature.
- 5.2 Rotate the red adjustment spindle with a small screwdriver – clockwise to increase temperature, anticlockwise to reduce it. One degree Celcius is about ¼ turn of the spindle.
- 5.3 When reducing temperature the red LED may go out while the incubator cools – this is normal.
- 5.4 Refer to the digital temperature display to check temperature. The display shows degrees Celcius in jumps of 0.2°. Adjust temperature with care – small differences have large effects on hatching performance.

Recommended temperatures:

Typical incubation period:

Hens	37.4 – 37.6°C	99.3 – 99.6°F	21 days
Pheasant	37.6 – 37.8°C	99.6 - 100°F	23-27 days
Quail	37.6 – 37.8°C	99.6 - 100°F	16-23 days
Ducks	37.4 – 37.6°C	99.3 – 99.6°F	28 days
Geese	37.4 – 37.6°C	99.3 – 99.6°F	28-32 days
Parrots:			
Amazons	36.8 – 37.0°C	98.3 – 98.6°F	24-29 days
Macaws	36.8 – 37.0°C	98.3 – 98.6°F	26-28 days
Love birds	36.8 – 37.0°C	98.3 – 98.6°F	22-24 days
African Grey	36.8 – 37.0°C	98.3 – 98.6°F	28 days
Eclectus	36.8 – 37.0°C	98.3 – 98.6°F	28 days

- 5.5 Developing embryos are fairly tolerant of short term temperature drops and the user need not be concerned about cooling that occurs when inspecting eggs. Temperatures above ideal can quickly have a serious detrimental effect on hatch rates and must be avoided.
- 5.6 The Octagon 20 or Octagon 40 may be used in conjunction with the Brinsea T20 temperature alarm system which gives audible and visual warning of mains failure, over temperature and under temperature. Contact your dealer or Brinsea Products for further details.

6.0 Humidity and Ventilation

Short term variations in humidity are not important. The average humidity over the incubation period needs to be near optimum to achieve the ideal weight loss. High humidity for the day or two of hatching is also important. Beware chronic, excessive humidity.

6.1 Two factors affect incubation humidity: water evaporation within the cabinet (from eggs as well as from additional water) and levels of ventilation. The water content of the air being drawn through the incubator will also have an effect.

6.2 There are three methods available to bird breeders to achieve correct humidity levels:

- a) Follow manufacturers guidelines for water and ventilation levels (see below).
- b) Measure humidity levels and adjust to match published guidelines for different species (see below).
- c) Monitor egg weight loss which varies as a direct result of humidity and correct against published weight loss figures for the species.

a) As a general guide for poultry set the ventilation control to about half open and maintain water in one of the two water channels in the Octagon 20 or two out of four channels in the Octagon 40. If the incubator is not full reduce the ventilation level accordingly. If the incubator is full of parrot (and parrotlike species) eggs the ventilation control should be about 2/3rds open. If fewer eggs are incubated reduce the ventilation level accordingly.

For all species ensure water in all channels for the last two days of incubation. Higher humidity levels are needed for hatching to prevent membranes drying too quickly. **Do not close the vent below 1/3rd when hatching.**

The above guidelines make no provision for different ambient conditions and are necessarily rather generalised but they are simple and often effective.

b) If measuring humidity levels directly be cautious of readings from low cost analogue or digital hygrometers. The best way of accurately measuring humidity levels at reasonable cost is to use a wet bulb thermometer. A specially designed wet bulb thermometer is available for the Octagon 20 and Octagon 40. Contact Brinsea or your local dealer for details. By comparing the temperature readings of a wet bulb (WB) thermometer with a normal (dry bulb) thermometer the relative humidity (RH) level can be found by using a table (see below).

WB temp. (°C)	WB temp. (°F)	RH level (%)
20	68	19
21	69.8	23
22	71.6	26
23	73.4	30
24	75.2	34
25	77	38
26	78.8	42
27	80.6	46
28	82.4	51
29	84.2	55
30	86	60
31	87.8	65
32	89.6	70
33	91.4	76
34	93.2	82
35	95	87
36	96.8	94
37	98.6	100

The figures above assume a dry bulb (incubation) temperature of 37°C (98.6°F).

Generally accepted incubation RH levels for species groups:

During incubation	Poultry	40-50% RH
	Parrots	35-45% RH
Hatching	All species	65% RH or more

For more specific information on particular species' requirements check the relevant literature.

- c) Eggs lose moisture through their shells and the rate of evaporation depends on the humidity levels around the eggs and the shell porosity. During incubation eggs need to lose a fixed amount of water which corresponds to a loss in weight of around 13-16% depending on species. By weighing eggs periodically during incubation it is possible to monitor and, if necessary, correct humidity levels to achieve the correct weight loss.

Weigh the eggs on the day they are set in the incubator, take the average weight and plot this on a graph (see example below). The ideal weight loss line can be plotted by joining the point representing initial average weight with the ideal hatch weight (13-16% less depending on species) with the x-axis representing the incubation period (in days).

By measuring actual average weights every few days the actual weight loss can be plotted and compared to the ideal weight loss line and corrections can be made. For example if the actual weight loss was greater than ideal (see graph below) then the air has been too dry and humidity levels need to be increased to compensate.

Typical ideal weight losses for species groups:

Poultry	13%
Parrots	15%
Waterfowl	14%

Egg weight loss chart

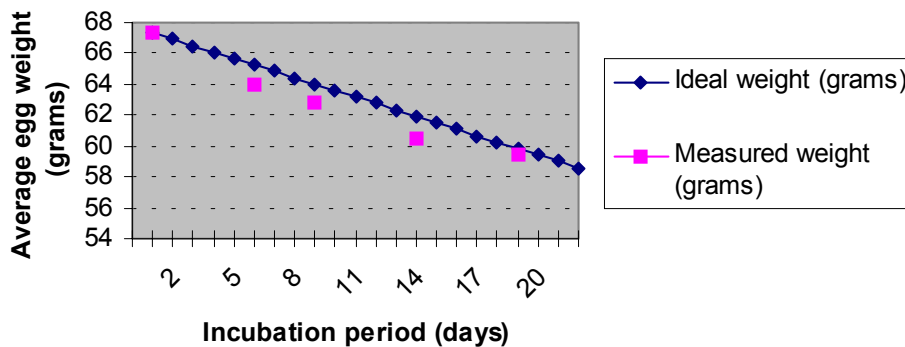

- 6.4 Of the three methods given above the most reliable is egg weight method and is recommended – particularly where poor hatch rates are experienced or if eggs of high value are being incubated.
- 6.5 Alter the setting of the ventilation control and have water in neither, both or one of the water channels to change the humidity level (see section 6.2a above)
- 6.6 In all cases the humidity for hatching needs to be high. Because of the short duration involved water/weight loss will not be significantly affected. High humidity is necessary to prevent membranes drying and hardening before the hatch fully emerges. Humidity will naturally increase as the first eggs begin to hatch and internal membranes begin to dry. This effect is in addition to the increased area of water evaporation from the water channels.

- 6.7 During hatching the high humidity levels will fall dramatically when the lid is opened and will take some time to build up. Resist the temptation to lift the lid frequently – leave for at least 6 hours between inspections.
- 6.8 The Brinsea H22 Automatic Humidity Management Module is available as an option on the Octagon 20 and Octagon 40 incubators. This module provides a readout of RH level and automatically controls water evaporation to maintain the user's setting.

7.0 Egg Setting

- 7.1 The Octagon 20 and Octagon 40 are designed to be as flexible as possible, accommodating eggs of different sizes up to (and including) goose eggs and in different orientations. Some experimentation may be necessary to maximise capacity.
- 7.2 Before setting eggs ensure that the incubator has been run for several hours and has stabilised at the correct temperature.
- 7.3 Set the eggs in rows between the plastic dividers. The dividers must be positioned such that the eggs rest on the tray bottom and are not pressured by the bar. The dividers prevent the eggs rolling. Eggs may be set on end (or at an angle) provided the large end of the egg is uppermost. Eggs rolling through a few degrees between the dividers as the incubator turns are not in danger.
- 7.3 Once the eggs have been set the temperature must not be adjusted for 24 hours to allow the eggs to warm. Check the water level every 3 days or so and temperature daily. Candle the eggs after 1/3rd of the incubation period has elapsed to reject clear, infertile eggs (see section 12).

8.0 Egg Turning

- 8.1 If using the incubator in conjunction with the autoturn cradle, follow installation and set-up procedures in section 3 above and the cradle will continuously turn the incubator and eggs until disconnected.
- 8.2 If incubating in the Octagon 20 without the autoturn cradle the eggs are rotated by rocking the incubator manually. Tip the incubator from 45° one side to 45° the other side at each “turn”. Turn three times each day starting on the second day.

9.0 Hatching

- 9.1 If hatching in the Octagon 20 or Octagon 40 unplug the autoturn cradle, remove the incubator from the cradle, place on the work surface in the upright position and remove the egg dividers two days before the hatch is due.
- 9.3 For maximum setting capacity, cleanliness, flexibility and performance a separate hatcher may be used. A second Brinsea Octagon 20, Octagon 10 or Hatchmaker incubators are recommended. Contact your dealer for details.
- 9.4 Eggs nearing hatch are slightly less sensitive to temperature variation and the hatching temperature can be reduced by up to 1°C (2°F) but this is not essential.
- 9.5 Hatching humidity levels need to be high (see section 6.0 above) but note that the ventilation control must be at least 1/3rd open.
- 9.4 When most eggs have hatched (12 to 48 hours) remove the hatchlings to a brooder. The Brinsea Cosylamp is ideal for poultry and waterfowl etc.. The Octagon 20 Parrot Rearing Module or Brinsea Parrot Brooder is recommended for exotics.

10.0 Cleaning Up

10.1 **IMPORTANT:**

DISCONNECT THE INCUBATOR AND BASE FROM THE MAINS POWER SUPPLY DURING CLEANING.

ENSURE THAT ALL ELECTRICAL PARTS ARE KEPT DRY.

NEVER WASH THE TRAYS, COVERS OR CABINET PARTS IN LIQUIDS OVER 50°C (120°F). DO NOT USE A DISHWASHER TO CLEAN TRAYS OR COVERS.

- 10.3 Following each hatch in the Octagon 20 or Octagon 40 remove and wash the egg basket, dividers and yellow base in Brinsea Incubation Disinfectant Solution. Wipe all other internal surfaces with a soft cloth soaked in the solution. Ensure that the instructions supplied with the fluid are followed. Periodically unscrew the four nuts retaining the fan cover, remove the cover and soak. Dust and fluff may be removed from the fan with a soft brush. To re-order the disinfectant phone 01934 823039 and quote part ref. 14.35 (100ml) or 14.36 (600ml)
- 10.4 If a separate hatcher is used the procedure above should still be followed every two months.
- 10.5 The exterior of the incubator and autoturn cradle may be cleaned with a damp cloth.
- 10.6 Always clean the incubator before storage and ensure that the unit is totally dry inside and out.

11.0 Servicing

IMPORTANT: THE HEATER IS AT MAINS VOLTAGE. NEVER DRILL INTO OR PUNCTURE THE CLEAR LID OF THE INCUBATOR. RISK OF ELECTRIC SHOCK.

- 11.1 Under certain conditions it is possible that condensation may form between the inner and outer clear top mouldings. The presence of water between these layers does not affect the performance of your incubator and does not pose an electrical hazard because the element itself is sealed and the live parts are not exposed. To disperse condensation leave the incubator running without eggs or water in a warm room.
- 11.2 In case of failure first check that the mains power supply is working and that the mains plug fuse is intact. If the problem persists contact your distributor or Brinsea Products Service Dept. The functional parts of the Octagon 20 and autoturn cradle are modular and parts are available and are readily exchanged by a suitably qualified person equipped with basic tools. Fitting instructions are supplied with replacement parts.
- 11.3 The digital temperature display is individually calibrated during manufacture but may be re-calibrated if required. To ensure optimal performance return the incubator to Brinsea Products Service dept. for re-calibration every two years. It is not recommended that this procedure is carried out by the user.
- 11.4 No lubrication or further servicing is required beyond the instructions above.

12.0 Troubleshooting

- 12.1 Poor hatching results are frustrating and can be caused by a large number of factors. The most common are given below but see the Brinsea publication 'Essentials of Incubation' for further details. Brinsea Products will not be held responsible for loss of eggs or chicks under any circumstances. However we will try to advise on incubation technique to improve results where necessary. Below are listed the commonest problems, their symptoms and solutions.
- 12.2 Glean as much information from the hatching results as possible to enable the problem to be analysed in detail. Record dates that eggs are set, incubator settings, dates of hatches, weight losses and the number and condition of hatchlings. Candle or break open unhatched eggs to estimate the extent of embryo development. The Brinsea Eglume candling lamps are available from your dealer.

12.3 General guides:

Observation	Likely Cause(s)	Solution(s)
No chicks hatch	Infertility, infection, drastically incorrect incubation settings, parent ill health.	Check egg viability – are similar eggs hatching naturally. Disinfect the incubator. Check incubator settings and procedures – particularly temperature.
Chicks hatch earlier than expected, deformities.	Incubation temperature too high	Reduce incubation temperature slightly (0.5°C)
Chicks hatch later than expected	Incubation temperature too low	Increase incubation temperature slightly (0.5°C)
Hatch dates widely spread	Different rates of development due to different storage times, incubation temperature variation.	Limit egg storage times. Check for incubation temperature variation – sunlight, large room variation etc.
Late stage 'death in shell'	Incorrect humidity, probably too high.	Try reducing average humidity levels (but see section 6 above)
Generally poor results	Incorrect incubation settings, poor parent bird health, inadequate egg turning,	Improve parent bird health, check all incubation settings, analyse egg weight loss to confirm humidity correct, check turning working correctly.

13.0 Specification

OCTAGON 20 and 40 Maximum Setting Capacities:

<u>Egg size</u>	<u>Octagon 20 capacity</u>	<u>Octagon 40 capacity</u>
Quail	60	120
Pheasant	40	80
Amazon/Macaw	36	72
Hen	24	48
Duck	20	40
Goose	9-12	18-24

Dimensions (inches):	Octagon 20 incubator only (Including Autoturn Cradle)	12.75 long x 9.25 wide x 9.5 high 16 long x 9.25 wide x 11 high)
	Octagon 40 incubator only (Including Autoturn Cradle)	25 long x 9.25 wide x 9.5 high 27.75 long x 9.25 wide x 11 high)

Weight:	Octagon 20 incubator only	4.2 Lbs
	Octagon 40 incubator only	4.6 Lbs
	Autoturn cradle	2.2 Lbs

Power Consumption	Octagon 20 max. (typical average)	45 Watts 23 Watts
	Octagon 40 max. (typical average)	90 Watts 45 Watts
	Autoturn cradle	4 Watts

Electrical Supply: 230v 50Hz or 115v 60Hz
as ordered

**Brinsea Products Inc., 704 N Dixie Ave., Titusville, FL 32796-2017 USA.
Phone. (407) 267-7009 Toll Free 1-888-667-7009 Fax (407) 267-6090
e-mail BrinseaUSA@aol.com, website www.Brinsea.co.uk**