

# **Brinsea**

## **Octagon 100 and 250 *Digital* high performance egg incubators**

### **Users instructions**

#### Contents

<u>Section</u>	<u>Subject</u>	<u>Page</u>
1	Introduction	2
2	Unpacking	3
3	Location and Installation	3
4	Storage of eggs	5
5	Temperature	5
6	Humidity and Ventilation	6
7	Egg setting	8
8	Egg turning	8
9	Hatching	9
10	Cleaning up	9
11	Servicing	10
12	Troubleshooting	11
13	Specifications	12

## 1.0 Introduction

These instructions detail the operation of your new Octagon 100 or Octagon 250 incubator and Autoturn base. Please read them carefully before setting up your machine to achieve best results and keep these instructions safe for future reference. This document includes recommended procedures for successful hatching but incubation involves the control and manipulation of a large number of factors and in certain circumstances different procedures may be necessary. Your incubator is designed to allow the user to vary the incubation conditions to suit a wide range of species in different ambient conditions and the specific set-up for every situation is beyond the scope of these instructions.

The differences between the Octagon 100 and 250 relate to size and capacity – all working parts are similar and any functional differences are described in these instructions. These advanced incubators are available with a number of factory fitted options (such as the Automatic Humidity and Temperature Alarm Modules) and in these cases separate operating instructions for these modules are supplied.

*Fig. 1 Functional features of the Octagon 100 and Autoturn base (shown with optional Humidity Control Module). Octagon 250 is functionally similar.*

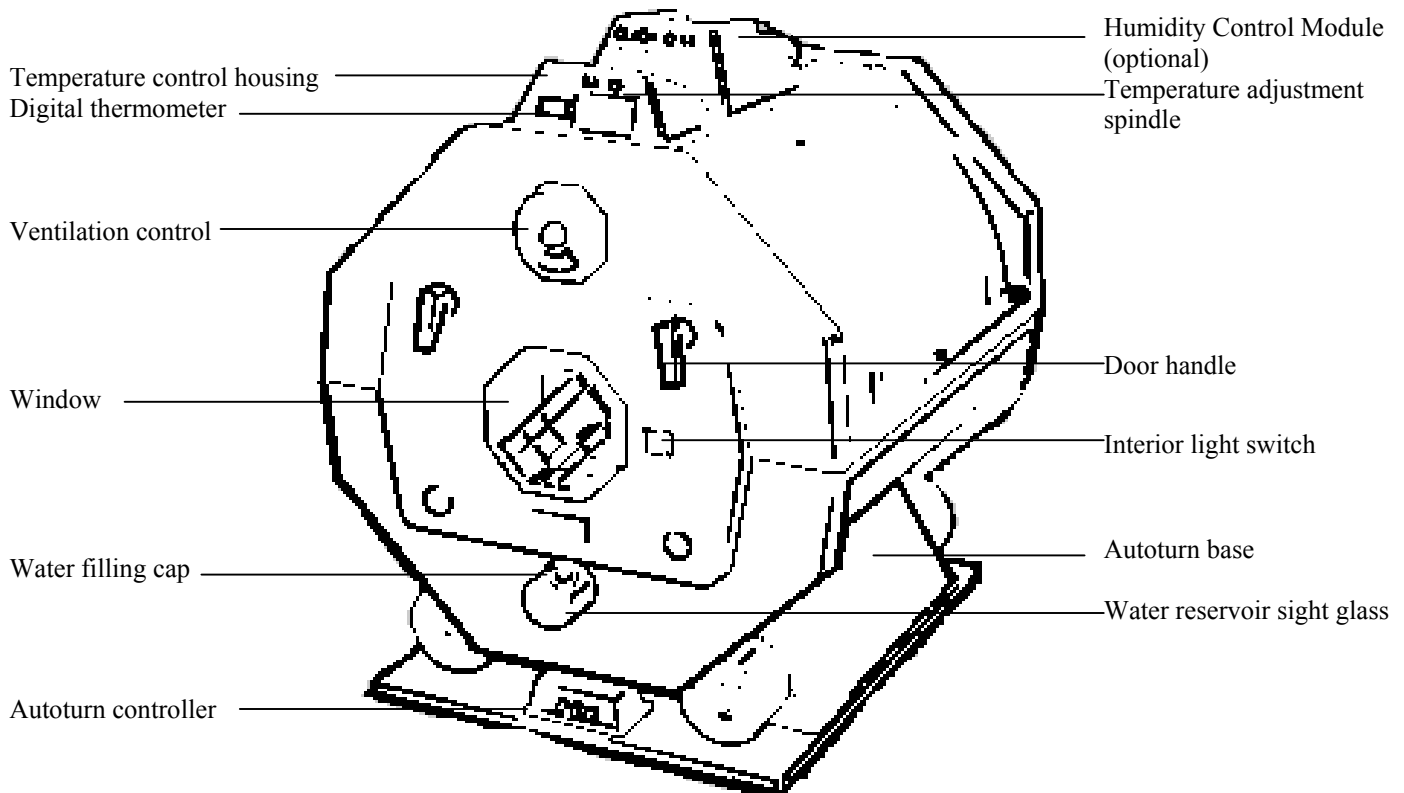

## 2.0 Unpacking

Your incubator has been supplied in protective packaging. Please remove all tape, strapping and packing from the incubator and parts. Retain the carton and packing materials to enable the unit to be repacked.

The Octagon 100 in standard configuration will include:

<u>Quantity</u>	<u>Item</u>
1	Incubator (including removable door)
1	Autoturn base
4	Universal egg trays
4	sets (of nine) egg dividers
4	pairs tray runners
3	Sheets evaporating pad
1	Guarantee card
1	Set of nuts, bolts and washers (for securing runners)

The Octagon 250 in standard configuration will include:

<u>Quantity</u>	<u>Item</u>
1	Incubator (including removable door)
1	Autoturn base
7	Universal egg trays
7	sets (of nine) egg dividers
7	pairs tray runners
3	Sheets evaporating pad
1	Guarantee card
1	Set of nuts, bolts and washers (for securing runners)

- 2.1 Please identify each part and check that they are all present and undamaged. If there are any parts damaged or missing please contact your retailer or Brinsea Products (at the address at the end of the document).
- 2.2 Note that if your incubator has been ordered with additional options (such as the Automatic Humidity Module or Temperature Alarm Module) separate instructions and component lists apply. Different egg tray options are also available (such as hatching covers and special trays for certain species) and check that these have been supplied correctly against your order.
- 2.3 Check also that the electrical supply matches the machine's requirements (marked on the technical label on the rear of the incubator and on the turning control housing on the Autoturn base).
- 2.4 Complete and return your guarantee card to register for your free 2 year guarantee.
- 2.5 Go to [www.Brinsea.com](http://www.Brinsea.com) and register as a free member of the Brinsea e-mail group to receive the latest news and information such as advance notice about new products, special offers, exclusive competitions and much more.

## 3.0 Location and Installation

Your incubator will give best results in a room free from wide temperature variations and with generous ventilation – particularly if several incubators are running at the same time. Ensure that the room temperature cannot drop on a cold night. Ideally thermostatically control the room at between 68 and 77°F (20 and 25°C). Never allow the room temperature to drop below 59°F (15°C) and ensure that the incubator cannot be exposed to direct sunlight.

- 3.1 Place the Autoturn base on a flat, level surface (workbench height is ideal) with the turning controls facing forwards. The Autoturn base is designed to locate on the top of the Brinsea Modular Hatcher where applicable. Plug the mains supply cable into a suitable outlet.

- 3.2 Place the incubator onto the Autoturn base as illustrated (fig. 1) so that the egg trays are approximately level. The cabinet is designed to self locate onto the wheels of the base with minimal fore and aft movement.
- 3.3 Where the Automatic Humidity Module is not fitted cut a 3" (70mm) strip of evaporating pad (illustration 3, pad A) across the short dimension of the sheet. Fold this strip in half and push the fold into the slot in the top of the tubular water reservoir (accessible from inside the cabinet). Ensure the fold is at the bottom of the reservoir. Fold the two upstanding pieces down flat onto the humidity tray (see illustration 3). Cut a second piece of evaporating pad (4 x 4" (100 x 100mm) for the Octagon 100, 4 x 6" (100 x 150mm) for the Octagon 250) and place on top of the first piece. The first piece acts as a wick drawing water from the reservoir, the second piece can be altered in size to alter humidity levels (see Humidity and Ventilation section) and can be replaced when dirty. Refer to the operating instructions accompanying the Automatic Humidity Module if fitted.

Fig. 3 Fitting evaporating pads (not applicable if automatic humidity is fitted)

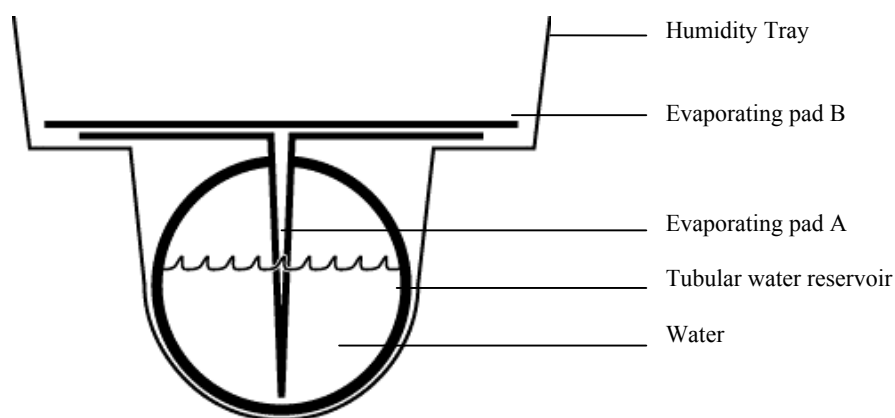

- 3.5 Remove the water filler cap from the top of the reservoir on the front of the incubator and fill with distilled water. Replace the cap.
- 3.6 Open the door and fit the tray runners to the fixed uprights by clipping the lugs on the runners into the slots on the uprights. The runners are handed: the difference being the black plastic end stop which must be at the back of the incubator cabinet. Once the runner positions are established they may be secured at the back with the short bolts, washers and nuts supplied to prevent the runner becoming dislodged when the egg trays are withdrawn.
- 3.7 Experiment with different runner heights to achieve maximum capacity for your eggs before filling the trays with eggs. Ensure that each runner is at the same height as its partner and that the runners are level front to back.
- 3.8 Remove the retaining screws holding the lamp cover on the inside of the door and fit with 4 AA type batteries (not supplied). Replace the cover and close the door by placing the bottom of the door in position first then pushing shut and securing by turning the handles downwards.
- 3.9 Plug incubator mains supply cable into a suitable outlet ensuring that the cable is not pulled tight. The fan will start and the red LED on the temperature control housing will illuminate continuously.
- 3.10 Press the Power button on the Autoturn base and the motor will cut in turning the incubator until it stops automatically after turning 45° from vertical.
- 3.11 Allow the incubator to run for at least an hour to stabilize the temperature before making adjustments or setting eggs (see below).

## 4.0 Storage of eggs

- 4.1 Store eggs in cool, damp conditions. Most species may be safely stored for up to 14 days before serious reductions in hatch rates are likely. Daily turning of stored eggs also helps maintain hatchability.
- 4.2 Discard cracked, mis-shaped and heavily soiled eggs (if possible). Only wash soiled eggs using a branded egg wash solution such as Brinsea Incubation Disinfectant Concentrate following the manufacturers instructions. It is essential to wash eggs in solution which is significantly warmer than the egg. Bear in mind that all solutions will remove the outer cuticle from the egg as well as the dirt and may leave the egg at greater risk from bacterial contamination in the future

## 5.0 Temperature

*Stable and correct temperature is essential for good results. Adjust with care.*

- 5.1 Your incubator is fitted with a high quality, individually calibrated digital thermometer. Be cautious of the accuracy of other thermometers used and have them calibrated if necessary.

**Note: your incubator may not be set to the correct temperature from the factory and the following procedure must be followed before setting eggs.**

- 5.2 As the incubator warms up and approaches its control setting the red LED will change from continuously on to flashing. Allow the incubator to stabilize for at least an hour before adjusting the temperature.
- 5.3 Rotate the red adjustment spindle with a small screwdriver – clockwise to increase temperature, anticlockwise to reduce it. 2°F (1°C) is about ¼ turn of the spindle.
- 5.4 When reducing temperature the red LED may go out while the incubator cools – this is normal.
- 5.5 Refer to the digital temperature display to check temperature. The display shows degrees Celsius in increments of 0.2°. Adjust temperature with care – small differences have large effects on hatching performance.

Recommended temperatures:

Typical incubation period:

Hens	37.5°C 99.5°F	21 days
Pheasant	37.7°C 99.8°F	23-27 days
Quail	37.7°C 99.8°F	16-23 days
Ducks	37.5°C 99.5°F	28 days
Geese	37.5°C 99.5°F	28-32 days
Parrots:		
Amazons	37.2°C 99.0°F	24-29 days
Macaws	37.2°C 99.0°F	26-28 days
Love birds	37.2°C 99.0°F	22-24 days
African Grey	37.2°C 99.0°F	28 days
Eclectus	37.2°C 99.0°F	28 days
Rhea	36.0°C 96.8°F	35-40 days
Emu	36.0°C 96.8°F	49-52 days
Ostrich	36.0°C 96.8°F	42-45 days

- 5.5 Developing embryos are fairly tolerant of short term temperature drops and the user need not be concerned about cooling that occurs when inspecting eggs. Temperatures above ideal can quickly have a serious detrimental effect on hatch rates and must be avoided.
- 5.6 The Octagon 100 and 250 incubators may be fitted with the T100 temperature alarm system which gives audible and visual warning of mains failure, over temperature and under temperature and also acts as a secondary

temperature control in the event of the primary control failing. The T100 can be retro-fitted if required (contact your dealer or Brinsea Products).

## 6.0 HUMIDITY AND VENTILATION

*Short term variations in humidity are not important. The average humidity over the incubation period needs to be near optimum to achieve the ideal weight loss. High humidity for the day or two of hatching is also important. Beware chronic, excessive humidity.*

- 6.1 Two factors affect incubation humidity: water evaporation within the cabinet (from eggs as well as from additional water) and levels of ventilation. The water content of the air being drawn through the incubator will also have an effect.
- 6.2 There are three methods available to bird breeders to achieve correct humidity levels:
- a) Follow manufacturers guidelines for water and ventilation levels (see below).
  - b) Measure humidity levels and adjust to match published guidelines for different species (see below).
  - c) Monitor egg weight loss which varies as a direct result of humidity and correct against published weight loss figures for the species.
- a) As a general guide for poultry set the ventilation control to about 1/3<sup>rd</sup> open and use an evaporating pad of about 4 x 4" (100 x 100mm). If the incubator is not full increase the size of the evaporating pad to compensate for the reduced water loss from the eggs. If the incubator is full of parrot (and parrotlike species) eggs the evaporating pad of 4 x 2½" (100 x 60mm) is appropriate with vent 1/3<sup>rd</sup> open. If the incubator is about half full use 4 x 4" (100 x 100mm). Ratites vary in humidity requirements but can often be incubated with no additional water.

For all species use a much larger evaporating pad (4 x 12" / 100 x 300mm) for the last two days of incubation. Higher humidity levels are needed for hatching to prevent membranes drying too quickly.

**Do not close the vent below 1/3<sup>rd</sup> when hatching.**

The above guidelines make no provision for different ambient conditions and are necessarily rather generalized but they are simple and often effective.

- b) If measuring humidity levels directly be cautious of readings from low cost analogue or digital hygrometers. The best way of accurately measuring humidity levels at reasonable cost is to use a wet bulb thermometer. By comparing the temperature readings of a wet bulb (WB) thermometer with a normal (dry bulb) thermometer the relative humidity (RH) level can be found by using a table (see below).

<u>RH level (%)</u>	<u>WB Temp °F</u>	<u>WB Temp °C</u>
20	69.1	20.6
25	71.6	22
30	74.1	23.4
35	76.5	24.7
40	78.8	26
45	80.8	27.1
50	82.9	28.3
55	84.9	29.4
60	86.7	30.4
65	88.5	31.4
70	90.1	32.3
75	91.9	33.3
80	93.6	34.2
85	95	35
90	96.6	35.9
95	98.1	36.7
100	99.5	37.5

The figures above assume a dry bulb (incubation) temperature of 37.5°C (99.5°F). If the incubation temperature is different compensate by adjusting the wet bulb temperature accordingly. For example: if using the incubator at 36°C with a wet bulb temperature of 26°C calculate the RH level using the 26°C wet bulb temperature: = 40%.

Generally accepted incubation RH levels for species groups:

During incubation	Poultry	40-50% RH
	Waterfowl	45-55% RH
	Parrots	35-45% RH
	Ratites	20-30% RH
Hatching	All species	65% RH or more

For more specific information on particular species' requirements check the relevant literature. Wet bulb thermometers are available from Brinsea Products – contact your dealer.

- c) Eggs loose moisture through their shells and the rate of evaporation depends on the humidity levels around the eggs. During incubation eggs need to loose a fixed amount of water which corresponds to a loss in weight of around 13-16% depending on species. By weighing eggs periodically during incubation it is possible to monitor and, if necessary, correct humidity levels to achieve the correct weight loss.
- Weigh the eggs on the day they are set in the incubator, take the average weight and plot this on a graph (see example below). The ideal weight loss line can be plotted by joining the point representing initial average weight with the ideal hatch weight (13-16% less depending on species) with the x-axis representing the incubation period (in days).

**Egg weight loss chart**

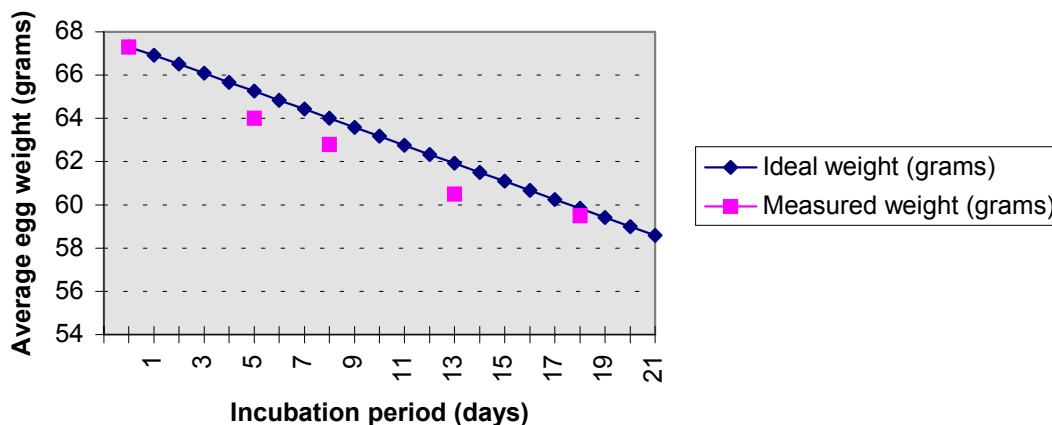

By measuring actual average weights every few days the actual weight loss can be plotted and compared to the ideal weight loss line and corrections can be made. For example if the actual weight loss was greater than ideal (see graph above) then the air has been too dry and humidity levels need to be increased to compensate.

Typical ideal weight losses for species groups:

Poultry	13%
Waterfowl	14%
Ratites	15%
Parrots	18%
Birds of prey	17%

- 6.4 Of the three methods given above the most reliable is egg weight method and is recommended – particularly where poor hatch rates are experienced or if eggs of high value are being incubated.
- 6.5 Alter the size of the evaporating pad and the setting of the ventilation control to change the humidity level (see section 6.2a above).
- 6.6 In all cases the humidity for hatching needs to be high. Because of the short duration involved water/weight loss will not be significantly affected. High humidity is necessary to prevent membranes drying and hardening before the hatch fully emerges. Humidity will naturally increase as the first eggs begin to hatch and internal membranes begin to dry. This effect is in addition to the increased area of water evaporation from the evaporating pad.
- 6.7 During hatching the high humidity levels will fall dramatically when the door is opened and will take some time to build up. Resist the temptation to open the door frequently – leave for at least 6 hours between inspections.
- 6.8 The Brinsea H122 Automatic Humidity Control is available as an option on the Octagon 100 and 250 incubators. This module provides a readout of RH level and automatically controls water evaporation to maintain the user's setting. Refer to the operating instructions accompanying the Automatic Humidity Module if fitted.

## 7.0 Egg Setting

- 7.1 The Octagon 100 and 250 are designed to be as flexible as possible, accommodating eggs of different sizes and in different orientations. Some experimentation may be necessary to maximize capacity.
- 7.2 Up to seven universal egg trays can be accommodated in the Octagon 250 and four in the Octagon 100 although with all but the smallest eggs, egg size will reduce the maximum number of trays. Additional universal trays are available from your dealer or Brinsea Products.
- 7.3 When using universal trays set the eggs in rows with the plastic dividers between each row. The dividers must be positioned such that the eggs rest on the tray bottom and are not pressured by the bar. The dividers prevent the eggs rolling. Eggs may be set on end (or at an angle) provided the large end of the egg is uppermost. Eggs rolling through a few degrees between the dividers as the incubator turns are not in danger. The slight jolt they may receive is less traumatic than normal disturbance in natural incubation.
- 7.4 Commercial egg 'flats' for partridge, hen and duck and special egg trays for ostrich and emu/rhea are available. Contact your dealer or Brinsea Products for details.
- 7.5 Egg trays must be positioned to distribute the weight of eggs evenly. The first tray should be central and subsequent trays must be added above and below the first.
- 7.6 Once the eggs have been set the temperature must not be adjusted for 24 hours to allow the eggs to warm. Check the water level in the clear sight glass and temperature daily and candle the eggs after 1/3<sup>rd</sup> of the incubation period has elapsed to reject clear, infertile eggs (see section 12).

## 8.0 Egg Turning

- 8.1 Follow installation and set-up procedures in section 3 above. The Autoturn base which compliments the Octagon 100 and 250 is designed to give flexible, low vibration turning whilst keeping all moving mechanisms outside the egg chamber for greater hygiene.
- 8.2 As standard the turning control will pause for around 45 minutes before rotating back. Each turn takes about 30 seconds. To bring the incubator to the upright position press the turning control power button off and then on. The incubator will then begin to rotate and when vertical the power button can be switched 'off' to halt the turning. To re-start the turning press the power back on again and the turning will continue as before.
- 8.3 The turning control can be altered to give pauses between rotations of 22, 45, 90 or 180 minutes. To adjust the turning interval follow the following procedure:

- a) DISCONNECT THE MAINS SUPPLY TO THE TURNING BASE
- b) Remove the turning control cover (4 screws).
- c) Identify the blue 4-way switch marked SW2, note that position 2 is connected.
- d) Carefully, with the use of tweezers or similar, unhook switch no.2 and hook down the link which corresponds to the desired interval from the list below.

Hook 1	22 minutes
Hook 2	45 minutes (standard)
Hook 3	90 minutes
Hook 4	180 minutes

- e) Reassemble the control housing and reconnect the power supply.
- 8.4 The light marked ! on the turning control housing will illuminate in the event of a turning motor overload. To clear the fault, press the power switch off and then on.
  - 8.5 In the event that the autoturn base cannot be used manual turning is possible by rotating the whole incubator onto the appropriate octagonal faces. The incubator should first be lifted out of the autoturn base and placed on a level counter.

## 9.0 Hatching

- 9.1 The Octagon 100 and 250 incubators may be used with separate hatchers or can be configured to hatch eggs. If eggs are to be hatched in the Octagon 100 or 250 universal egg trays complete with hatching covers (available separately) must be used to confine the chicks. The height of the hatching covers limits the capacity of the Octagon 100 and 250 to 2 and 3 trays respectively.
- 9.2 If hatching in the Octagon 100 or 250 switch off the automatic turning, remove the egg dividers and fit hatching covers two days before the hatch is due. Place the eggs on foam pads (supplied separately).
- 9.3 For maximum setting capacity, cleanliness, flexibility and performance a separate hatcher is recommended. The Brinsea Modular hatchers (both standard and ratite versions) are designed to compliment the Octagon 100 and 250 incubators in both performance and function. Contact your dealer or Brinsea Products for details.
- 9.4 Eggs nearing hatch are slightly less sensitive to temperature variation and the hatching temperature can be reduced by 1°C (2°F) to compensate for high metabolic heat.
- 9.5 Hatching humidity levels need to be high (see section 6 above) but note that the ventilation control must be at least 1/3<sup>rd</sup> open.
- 9.6 When most eggs have hatched (12 to 48 hours) remove the hatchlings to a brooder. The Brinsea Cosylamp is suitable for poultry and waterfowl etc.. The TLC-4 Brooder or Octagon 20 Parrot Rearing Module are recommended for exotics.

## 10.0 Cleaning Up

### 10.1 **IMPORTANT:**

DISCONNECT THE INCUBATOR AND BASE FROM THE MAINS POWER SUPPLY DURING CLEANING.

ENSURE THAT ALL ELECTRICAL PARTS ARE KEPT DRY.

NEVER WASH THE TRAYS, COVERS OR CABINET PARTS IN LIQUIDS OVER 120°F (50°C). DO NOT USE A DISHWASHER TO CLEAN TRAYS OR COVERS.

- 10.3 Following each hatch in the Octagon 100 or 250 remove and wash the trays and hatching covers in Brinsea Incubation Disinfectant Solution, discard the foam hatching mats and the upper evaporating pad. Wipe all internal surfaces with a soft cloth soaked in Brinsea Incubation Disinfectant Solution. If necessary remove the water reservoir by lifting at the back of the cabinet. Remove and soak in sterilising solution. Periodically unscrew the four nuts retaining the fan cover, remove the cover and soak. Dust and fluff may be removed from the fan with a soft brush.
- 10.4 If a separate hatcher is used the procedure above should still be followed every two months with the upper evaporating pad being replaced every month.
- 10.5 The exterior of the incubator and autoturn base may be cleaned with a damp cloth.
- 10.6 Always clean the incubator before storage and ensure that the unit is totally dry inside and out.

## 11.0 Servicing

- 11.1 No routine servicing is necessary beyond the points given in section 10 above.
- 11.2 In case of failure first check that the mains power supply is working. If the problem persists contact your distributor or Brinsea Products Service Dept.  
The functional parts of the Octagon 100 and 250 are modular and parts are available and are readily exchanged by a suitably qualified person equipped with basic tools.  
Fitting instructions are supplied with replacement parts.
- 11.3 The schematic below shows the electrical connections between the working parts of the incubator to assist in the replacement of any working part.

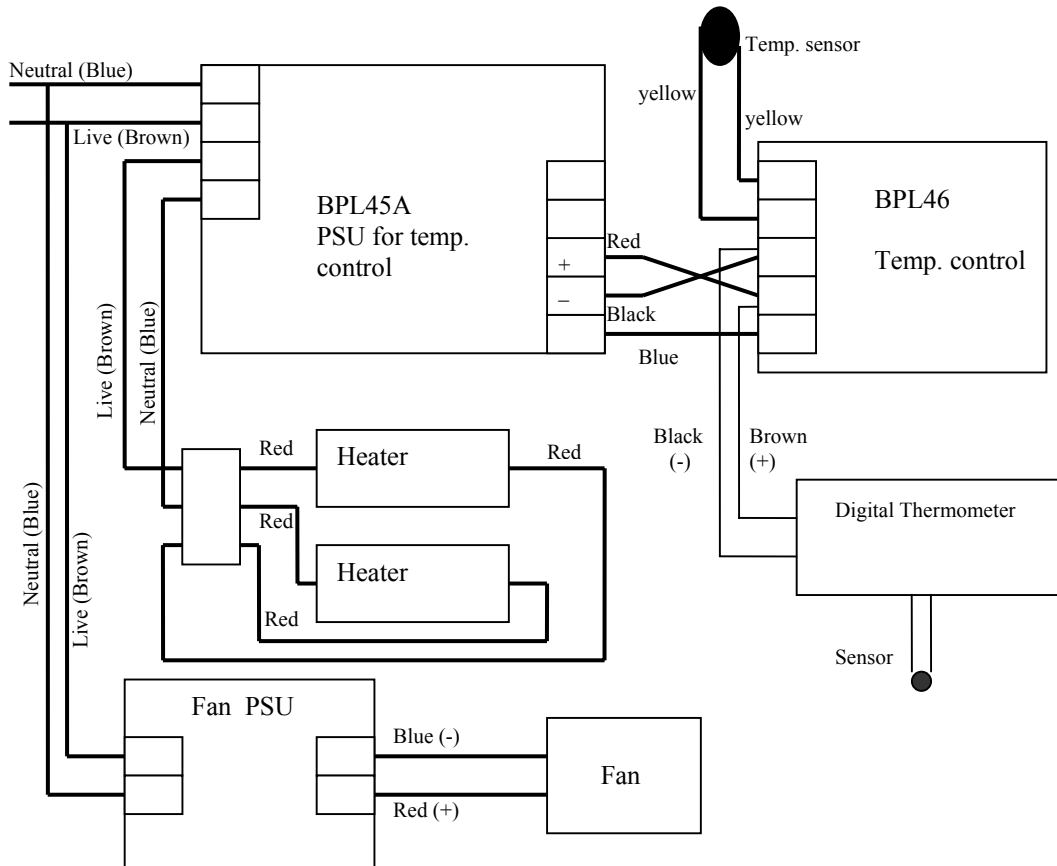

## 12.0 Troubleshooting

- 12.1 Poor hatching results are frustrating and can be caused by a large number of factors. The most common are given below. Brinsea Products will not be held responsible for loss of eggs or chicks under any circumstances. However we will try to advise on incubation technique to improve results where necessary.
- 12.2 Gather as much information from the hatching results as possible to enable the problem to be analyzed in detail. Record dates that eggs are set, incubator settings, dates of hatches, weight losses and the number and condition of hatchlings. Candle or break open unhatched eggs to estimate the extent of embryo development. The Brinsea Cool-Lume or Egg-Lume candling lamps are available from your dealer.

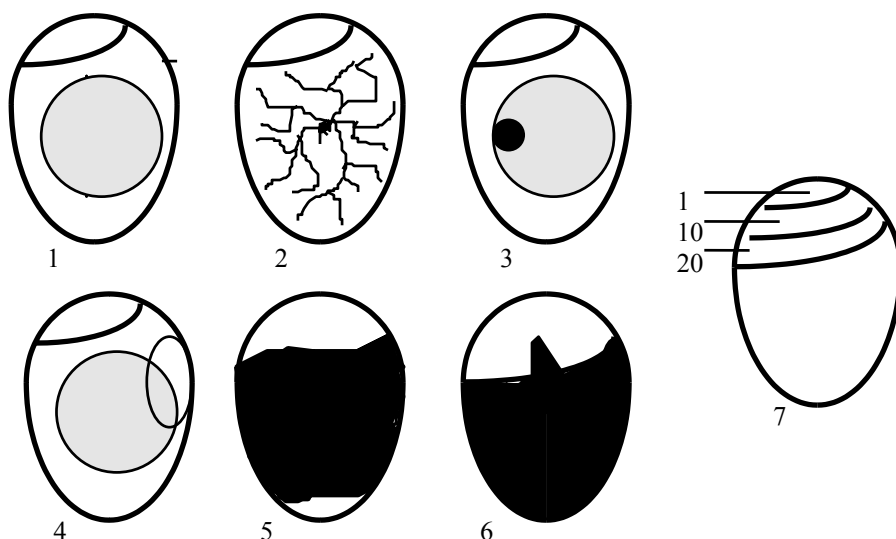

- 1) Clear when candled - probably infertile (or very early death) when candled at 8 days
- 2) Fertile with red blood vessels - after 8 days
- 3) Red or black staining - early death when candled at 8 days
- 4) Embryo with red blood 'ring' - early death when candled at 8 days
- 5) Dark outline with ill defined detail - late death (10-16 days)
- 6) Live embryo with bill in air sack - due to hatch in 24-48 hours
- 7) Normal development of the air pocket according to number of days

### 12.3 Some general guides:

Observation	Likely Cause(s)	Solution(s)
No chicks hatch	Infertility, infection, drastically incorrect incubation settings, parent ill health.	Check egg viability – are similar eggs hatching naturally. Disinfect the incubator. Check incubator settings and procedures – particularly temperature.
Chicks hatch earlier than expected, deformities.	Incubation temperature too high	Reduce incubation temperature slightly 1°F (0.5°C)
Chicks hatch later than expected	Incubation temperature too low	Raise incubation temperature slightly 1°F (0.5°C)
Hatch dates widely spread	Different rates of development due to different storage times, incubation temperature variation.	Limit egg storage times. Check for incubation temperature variation – sunlight, large room variation etc.
Late stage 'dead in shell'	Incorrect humidity, probably too high.	Try reducing average humidity levels (but see section 6 above)
Generally poor results	Incorrect incubation settings, poor parent bird health, inadequate egg turning,	Improve parent bird health, check all incubation settings, analyse egg weight loss to confirm humidity correct, check turning working correctly.

### 13.0 Specification

#### **OCTAGON 100 Maximum Setting Capacities:**

##### **With universal trays**

Egg size	No. eggs per tray	Max No. trays	Total
Quail	150	4	600
Partridge	84	4	336
Pheasant	70	4	280
Hen	54	3	162
Duck	35	3	105
Turkey	35	3	105
Goose	16	3	48

##### **With special trays**

Pheasant	78	4	312
Hen	60	3	180
Turkey	40	3	120
Emu/Rhea	9	2	18
Ostrich	6	1	6

#### **OCTAGON 250 Maximum setting capacities**

##### **With universal trays**

Egg size	No. eggs per tray	Max No. trays	Total
Quail	150	7	1050
Partridge	84	7	588
Pheasant	70	7	490
Hen	54	7	378
Duck	35	5	175
Turkey	35	5	175
Goose	20	5	100

##### **With special trays**

Pheasant	78	7	546
Hen	60	5	300
Turkey	40	5	200
Emu/Rhea	9	4	36
Ostrich	6	2	12

#### **Octagon 100**

#### **Octagon 250**

##### **Dimensions :**

Incubator only	21¾ x 25½ x 23" high	28 x 25½ x 28" high
Including autoturn base	21¾ x 25½ x 25½" high	28 x 25½ x 32½" high

##### **Weight:**

Incubator only	26.9Lbs	37.1Lbs
Autoturn base	7.9Lbs	

##### **Power Consumption**

Maximum	100 Watts	150 Watts
Typical average	50 Watts	75 Watts
Autoturn base max.	15 Watts	15 Watts

**Electrical Supply:** 230v 50Hz or 115v 60Hz as ordered

**Brinsea Products Inc., 704 N Dixie Ave., Titusville, FL 32796-2017 USA.  
Phone. (321) 267-7009 Toll Free 1-888-667-7009 Fax (321) 267-6090  
e-mail BrinseaUSA@aol.com, website www.Brinsea.com**