

Brinsea

TLC-40 Eco / TLC-50 Eco

Thermal

Life-support

Cabinet

User instructions

Contents

<u>Section</u>	<u>Subject</u>	<u>Page</u>
1	Introduction	2
2	QUICK REFERENCE	2
3	Unpacking	4
4	Location and Assembly	5
5	Digital Control System	7
6	Temperature	7
7	Humidity and Ventilation	8
8	Introducing Young Birds	9
9	Cleaning up	9
10	Servicing and Calibration	10
11	Specification	11

IMPORTANT NOTICE

Brinsea Products Ltd and its agents or distributors will not be responsible for loss of animals in the event of failure however caused and the user is advised to arrange his own insurance cover where loss of power or mechanical or electrical failure might result in unacceptable losses.

1 Introduction

These instructions detail the operation of your new TLC-40 Eco or TLC-50 Eco digital brooder. Please read these instructions carefully before setting up your machine to achieve best results and keep these instructions safe for future reference. Your TLC Eco brooder is designed to allow the user to vary the environmental conditions to suit a wide range of species and the specific set-up for every species is beyond the scope of these instructions. There are a range of books and veterinarian texts available covering animal and avian hand rearing and recovery techniques

Fig. 1 Functional features of the TLC-40 Eco and TLC-50 Eco (40 model shown)

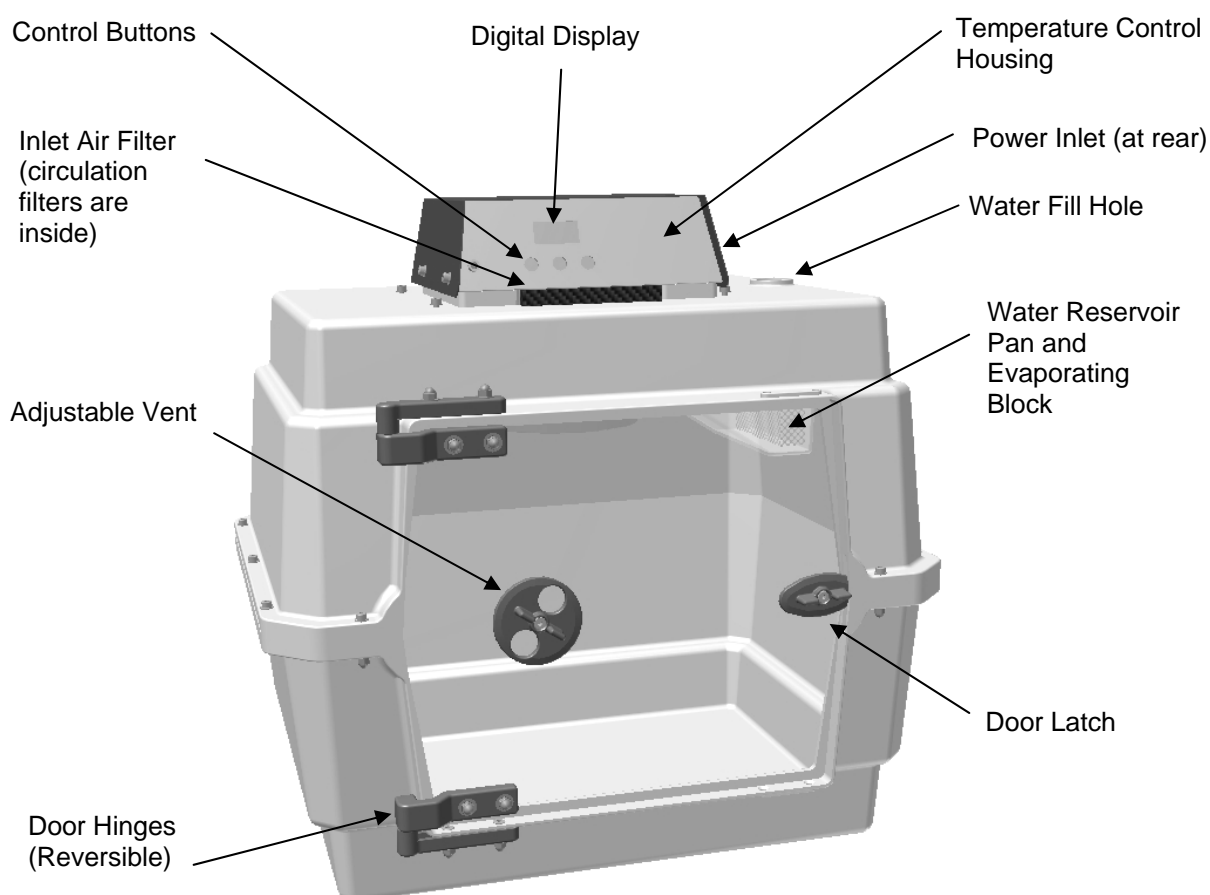

2 Quick Reference (please read relevant section for detail)

This quick reference is intended to allow users familiar with Brinsea TLC brooders to quickly set up the brooder and learn the key features of the control system. Please read the rest of the instructions to obtain a full understanding of each feature. **DO NOT COVER THE BROODER. FOR INDOOR USE ONLY.**

- 1) Carefully unpack the brooder parts (section 3)
- 2) Assemble the cabinet (section 4)
- 3) Fit the power lead

MAIN MENU – QUICK REFERENCE

	PRESS BOTH BUTTONS TO UNLOCK THE MAIN MENU
	SELECT THE OPTION / RETURN TO THE MENU.
	GO FORWARD ONE SCREEN / INCREASE THE VALUE / DISPLAY IN CELSIUS.
	GO BACK ONE SCREEN / DECREASE THE VALUE / DISPLAY IN FAHRENHEIT.

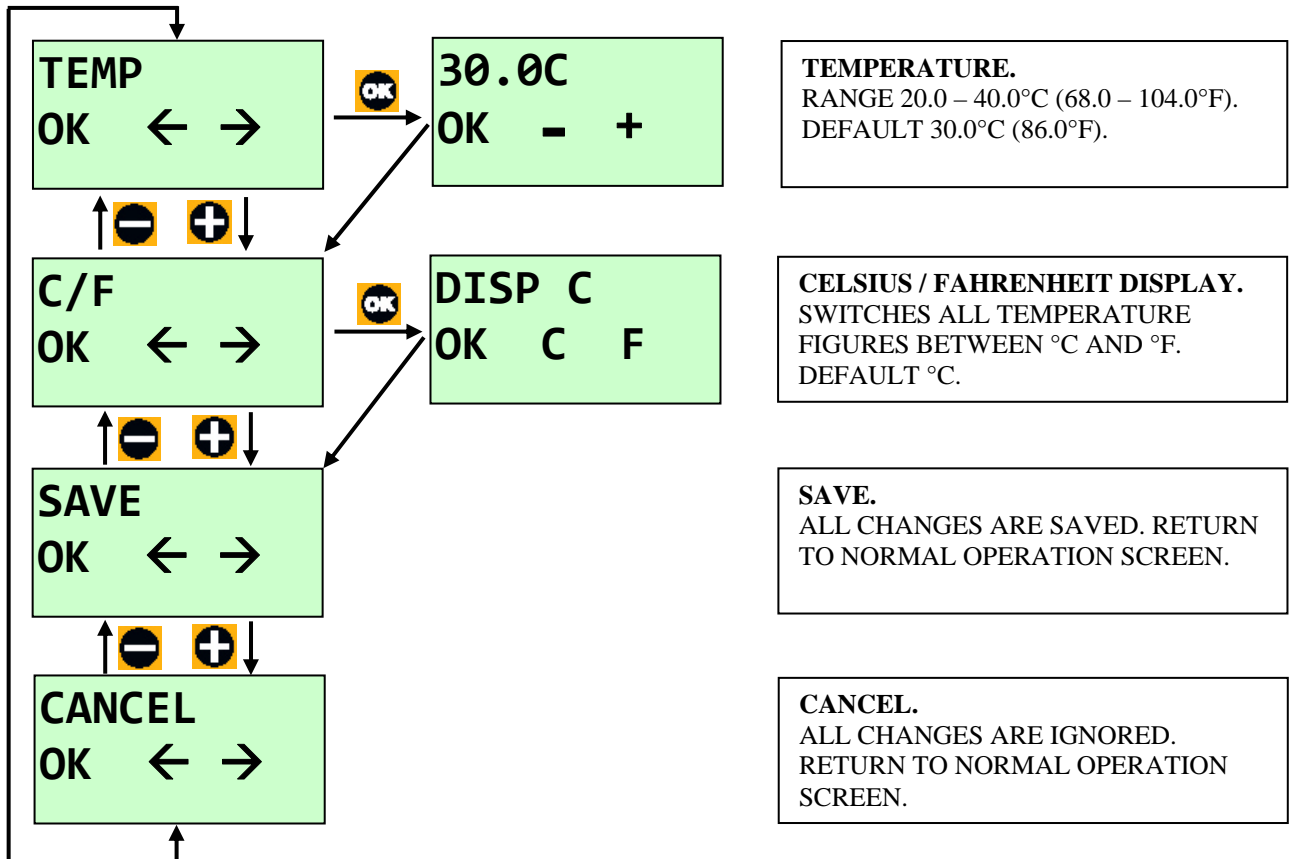



3 Unpacking

Your brooder has been supplied in protective packaging. Please remove all tape, strapping and packing from the brooder and parts. Retain the carton and packing materials to enable the unit to be repacked.

Your brooder will include as standard:

Quantity	Item
1	Brooder top assembly (with 3 air filters fitted)
1	Cabinet base
1	Door
1	Hinge socket
1	Fastener and tool kit
1	Mains cable
1	Water pan
1	Evaporating block
1	Water funnel

Fastener and Tool Kit Contents:

Quantity TLC-40	Quantity TLC-50	Item
2	2	 M5 x 16mm countersunk screws
2	2	 M5 flat washers
2	2	 M5 domed nuts
12	16	 M4 x 30mm cap-headed screws
12	16	 M4 star washers
12	16	 M4 domed nuts
1	1	3mm hex key
1	1	4mm hex key
1	1	7mm / 8mm wrench

- 3.1 Please identify each part and check that they are all present and undamaged. If there are any parts damaged or missing please contact your retailer or Brinsea Products (at the address at the end of the document).
- 3.2 Check also that the electrical supply matches the machine's requirements (marked on the technical label next to the power inlet socket).
- 3.3 To register your new Brinsea product please visit www.brinsea.com and follow the link under Customer Service on the top navigation of the home page to qualify for your free 2 year guarantee. If you do not have access to the internet please call 1-888-667-7009.
- 3.4 Go to www.Brinsea.com and register as a free member of the Brinsea Email Group to receive the latest news and information such as advance notice about new products, special offers, exclusive competitions and much more.

4 Location and Assembly

4.1 Your brooder will give best results in a room free from wide temperature variations and with generous ventilation – particularly if several incubators / brooders are running at the same time. Ensure that the room temperature cannot drop on a cold night. Ideally thermostatically control the room at between 68 and 77°F (20 and 25°C). Never allow the room temperature to drop below 15°C (59°F) and ensure that the brooder cannot be exposed to direct sunlight.

4.2 Assemble the cabinet using the tools and fasteners provided. Follow the diagrams. Do not over-tighten fasteners.

4.3 The door is hinged at the left as supplied but may be reversed to provide better access if required. Fit the top hinge socket to the cabinet using the M5 x 16mm countersunk screws, M5 flat washers and M5 dome nuts.

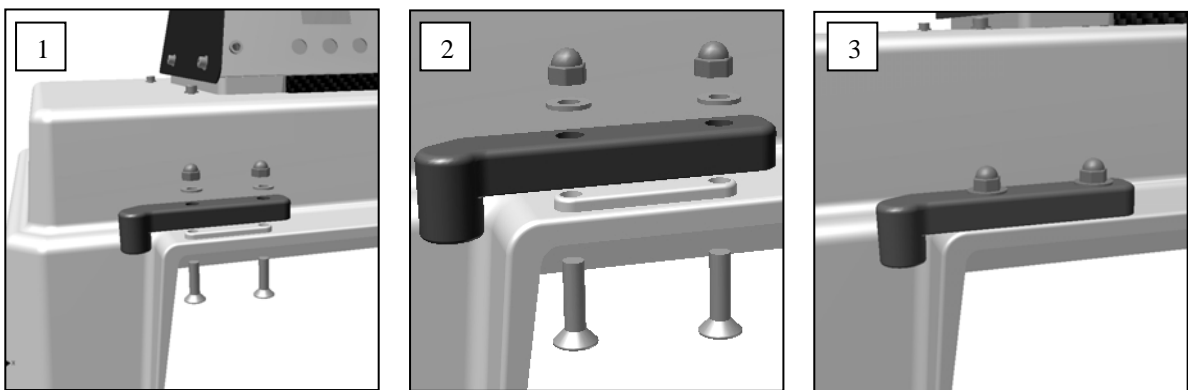

4.4 Place the door in the lower hinge and close the latch. Lower the top cabinet down onto the other parts.

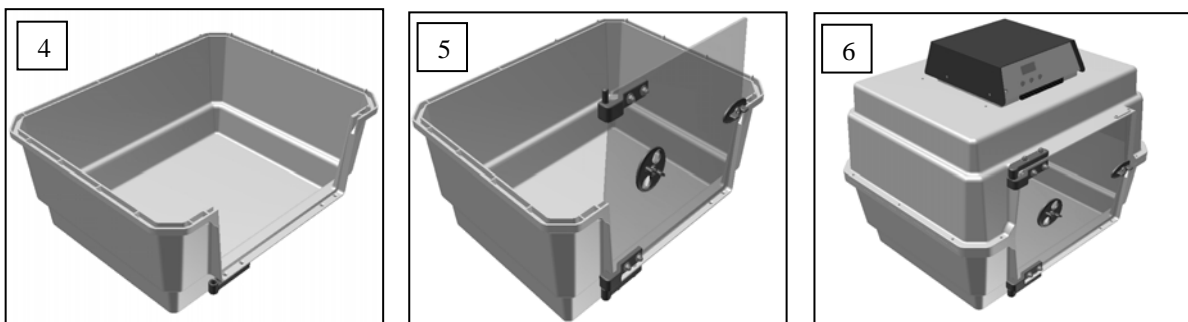

4.5 Fit the M4 x 30mm cap-headed screws, star washers and dome nuts into each set of holes around the edge of the cabinet. Tighten enough to prevent them spinning. This creates an air tight seal around the cabinet.

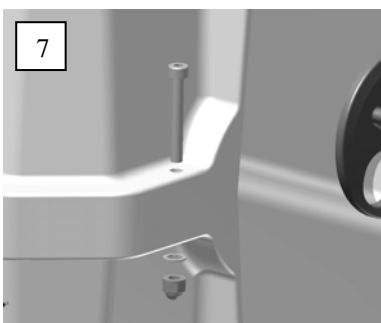

- 4.6 Place the white evaporating block upright in the clear water pan. Open the door and lift the pan into position, it pushes up and across into two slots on the heater enclosure. The pad may need to be softened with a little water to help it flatten while the pan is fitted. The pan is located in this manner to help prevent accidental removal by animals.

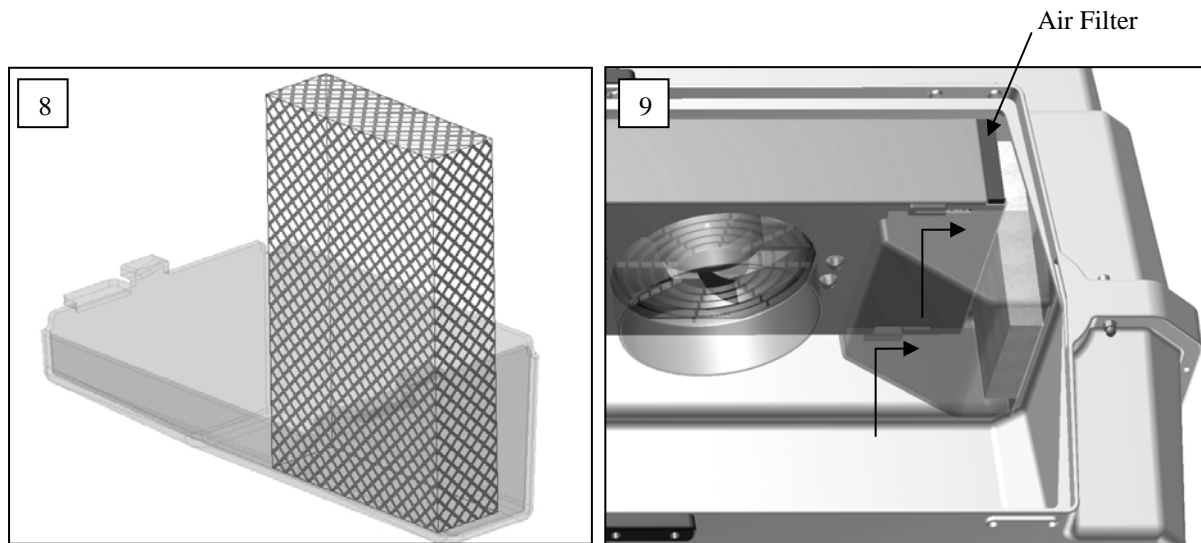

- 4.7 Your brooder is supplied with air filter media fitted at the air inlet (see fig 1) and at each end of the heater enclosure (see picture 9 above). For details of filter replacement see the Servicing section.
- 4.8 Place the brooder on a scratch and moisture resistant surface. Worktop height is ideal.
- 4.9 Connect the mains cable to the inlet. Ensure the connector is pushed fully home in its socket.
- 4.10 The fan will start and the display will show the current temperature inside the brooder.
- 4.11 Allow the brooder to run for at least an hour to stabilise the temperature before making adjustments or introducing animals.

5 Digital Control System

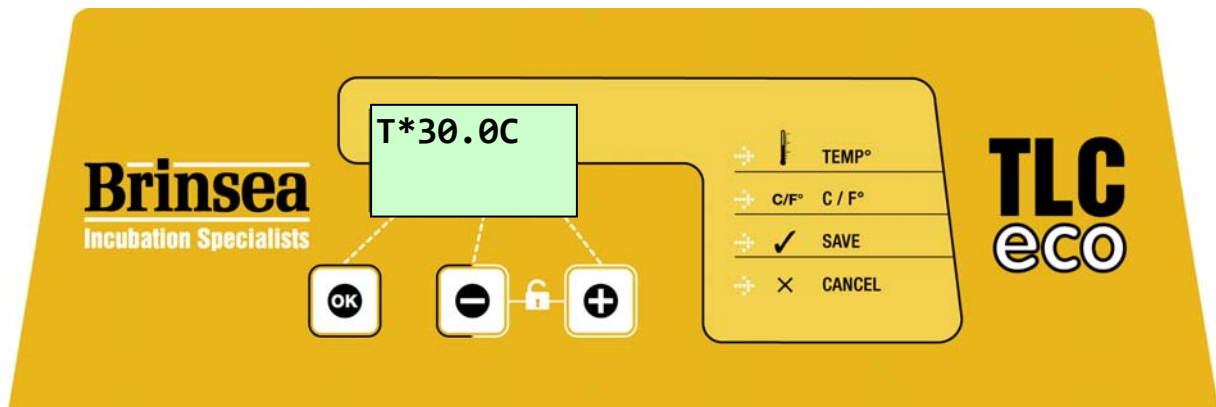

The TLC Eco control system utilises a highly accurate, calibrated sensor for temperature. Be cautious of low cost analogue or digital thermometers when comparing them with the brooder display readings.

5.1 NORMAL OPERATION – Temperature is continuously displayed.

The asterisk “*” adjacent to the temperature reading shows when the heater power is on. When warming the asterisk will be continuously on, once warmed up the asterisk will slowly flash as the heater is pulsed to maintain the correct temperature. When reducing the temperature setting the asterisk may go off, this is normal.

5.2 CHANGING SETTINGS – The Main Menu allows the various settings to be modified and saved. All changes are retained in the event of a power cut.

To access the Main Menu press the + and – buttons simultaneously to unlock the display. For full details of menu settings please refer to the guide on page 3.

6 Temperature

Stable and correct temperature is essential for good results. Adjust with care.

- 6.1 Note: your brooder may not be set to the correct temperature from the factory and the following procedure must be followed before introducing animals.
- 6.2 As the brooder warms up and approaches its control setting the heater on asterisk “*” will change from continuously on to flashing. Allow the brooder to stabilise for at least an hour before adjusting the temperature.
- 6.3 Press the - and + buttons simultaneously to unlock the main menu. Press OK to select the temperature screen and adjust as necessary using the + and – buttons. Press OK to return to the Main Menu and then scroll down to Save. Press OK to save the changes. When reducing temperature the asterisk may go out while the brooder cools – this is normal.
- 6.4 Refer to the digital temperature display to check temperature. The display shows the air temperature in increments of 0.1°.
- 6.5 The Display can be switched to show all temperature settings in degrees Fahrenheit. Press the - and + buttons simultaneously to unlock the main menu. Scroll to the C/F option and press OK to select the C/F display screen. Press the + button to select °F or the – button to select °C. Press OK to return to the Main Menu and then scroll down to Save. Press OK to save the changes.

- 6.6 **TEMPERATURE GUIDELINES FOR BROODING HATCHLING CHICKS.** As a general rule a newly hatched chick will need a brooder temperature a little lower than incubation temperature, about 35-36°C (95-97°F) and the temperature can be reduced progressively at about 0.5°C (1°F) per day until it is fully feathered or no longer requires supplementary heat. In warm ambient conditions this will be sooner than in cold climates. When brooding temperatures are just above room temperature the asterisk heater indicator may go out (indicating that no heat is being applied). This indicates that the birds are ready to be moved to a nursery cage. If room temperature then drops (e.g. at night) then the birds can be kept warm by replacing them into the TLC brooder.
- 6.7 Where there is to be a continuous throughput of birds of differing stages of development, several TLC brooders can be set to different temperatures and the birds moved to cooler units as they grow.
- 6.8 The Recommended staged temperature settings for most parrots and falcons:
- | | | | |
|-------------|--------------|---------------|---------------|
| Days 1 to 5 | Days 6 to 10 | Days 11 to 15 | Days 16 to 25 |
| 97°F (36°C) | 91°F (33°C) | 85°F (29.5°C) | 80°F (27°C) |

These temperatures have been found to promote optimal health and growth from newly hatched chicks and are a little higher than may be found in nests. Where birds are taken from a nest after more than a few days, the temperature setting will usually need to be a few degrees lower to prevent heat stress. The recommendations above are for guidance only, always observe the chick's behaviour (see below) to verify setting.

Temperatures too high can cause heat stress, dehydration, deformities or haemorrhaging under the skin. Low temperature may reduce appetite and retard growth. Observation of the bird is the best guide to its comfort. Chicks try to huddle together if cold and move about seeking parental warmth. Chicks too warm separate and pant. In either case they will complain vocally. Comfortable birds will lie quietly sleeping with wings loosely folded at the sides, usually in contact with one another.

- 6.9 Developing chicks are fairly tolerant of short-term temperature drops but care should be taken about cooling that occurs during feeding or inspection. Keep the room warm, hold the bird in a cloth to prevent chilling from cold hands and use warmed feeding utensils.

7 Humidity and Ventilation

Elevated air temperatures in the TLC brooder will reduce the relative humidity level(RH) and can cause dehydration. A water reservoir is fitted to counteract this effect.

- 7.1 Your TLC brooder is fitted with a water reservoir (see fig.1) which humidifies air as it is drawn into the heater enclosure. Use a solution of Brinsea Incubation Disinfectant (1part concentrate to 100 parts water) in the water reservoir (pan) to inhibit bacterial build-up. It is recommended that the reservoir is topped up with solution daily to reduce dehydration. This can be a particular problem with chick(s).
- 7.2 The brooder and its occupants need not be disturbed to fill the water pan. Use the funnel provided to pour water through the water fill point in the top of the brooder (see fig. 1) directly onto the evaporating block and into the water pan. Push the funnel down gently into the hole to make sure the water pours directly in. Clean up any spilled water from the top of the brooder immediately.
- 7.3 To further increase humidity levels within the brooder the water reservoir is fitted with an evaporating block of absorbent paper mesh as standard. This block may be set across the water pan (instead of upright) or removed entirely to give lower humidity levels if condensation forms. The block can provide a breeding ground for bacteria. In addition to the use of Brinsea Incubation Disinfectant concentrate in the water, it is recommended that the block is replaced every 2 months of use.
- 7.4 An adjustable vent is fitted to the door of the brooder which may be opened or closed to give greater control of humidity (close vent to increase) and fresh air flow. The vent may be fully closed as fixed ventilation is also provided.

8 Introducing Young Birds

Once the correct temperature has been established and the air humidified the TLC brooder is ready for use.

- 8.1 For newly hatched chicks use small plastic tubs such as ice-cream or butter / spread containers lined with paper towel. Young birds of similar age and size can be placed together and benefit from the warmth and comfort. If disparity in size is too great the smaller animal is at risk of being crushed or smothered.
- 8.2 For larger chicks and adult birds line the base of the TLC brooder with paper towelling and place the bird(s) directly on this. The brooder cabinet material is smooth and designed to be easy to clean.
- 8.3 Change paper towel at each feed or at least four times a day.
- 8.4 Follow feeding regimes recommended for your species ensuring the highest standards of hygiene at all times.
- 8.5 In order to maintain maximum air-flow the air-flow filters should be checked once a week for dust or down, and cleaned if necessary.

9 Cleaning Up

IMPORTANT:

DISCONNECT THE BROODER FROM THE MAINS POWER SUPPLY DURING CLEANING. RISK OF ELECTRIC SHOCK! ENSURE THAT ALL ELECTRICAL PARTS ARE KEPT DRY.

- 9.1 Following each brood in your TLC brooder remove all debris from the floor. Wipe all internal surfaces with a soft cloth soaked in 100:1 Brinsea Incubation Disinfectant solution. Filters should be inspected on a weekly basis and be cleaned if necessary. Remove all three filters and gently hand wash in warm water then allow them to dry before use. Filters need replacing every six months. Immerse and soak any nest tubs in disinfectant solution. The exterior of the TLC brooders may be cleaned with a damp cloth.

USE WATER BASED DISINFECTANTS ONLY WHEN CLEANING

- 9.2 Always clean the TLC brooder before storage and ensure that the unit is totally dry inside and out or damage may occur to the components.
- 9.3 For deeper cleaning the base of the cabinet and the door may be removed by releasing the fasteners. See section 4 for assembly guide. The cabinet base and the door may be wet-cleaned with mild detergent and then disinfected with water based disinfectant solution such as Brinsea Incubation Disinfectant.

Replacement filters, evaporating blocks and disinfectant solution are all available from Brinsea Products at the address at the end of this document or from your Brinsea agent.

10 Servicing and Calibration

- 10.1 Although it is not regarded as necessary for routine cleaning, the heater enclosure may be safely removed to allow the heater and fan to be dusted. **Disconnect the power lead.** Remove the water pan. Loosen the 4 cap-head screws (on top of the white plastic cabinet, not the grey control box) as shown and then finally remove each one **while supporting the metal enclosure inside**. The metal enclosure will fall if not held and may damage the brooder.
- 10.2 Carefully place the brooder on its top and then lift out the metal heater enclosure. The fan assembly may then be hinged over toward the front of the machine so that the heating element and fan blades may be dusted with a soft brush. **USE NO LIQUIDS. DO NOT DISTURB THE TEMPERATURE SENSOR.**

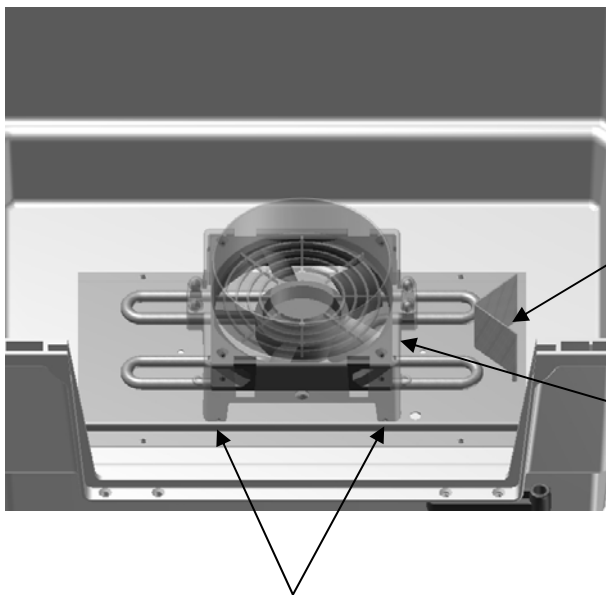
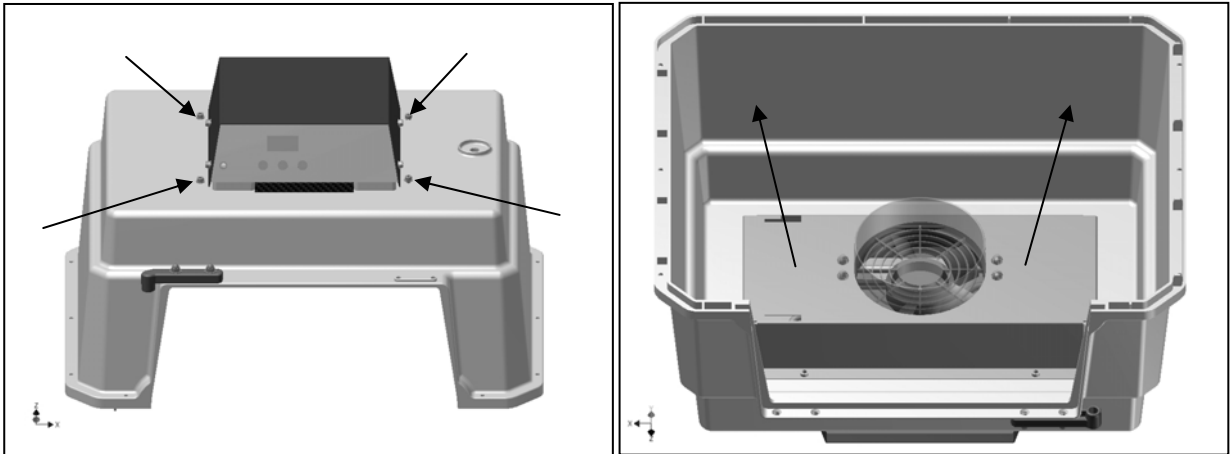

DO NOT DISTURB SENSOR

Fan assembly may be hinged out on its cables to allow fan and heater to be dusted with a soft brush

Fan assembly is located by 4 pegs in the feet of the clear moulding

- 10.3 Once the heater area has been dusted the fan assembly must be relocated by ensuring the 4 pegs on the clear moulding fit into the corresponding holes in the metal base plate.
- 10.4 ENSURE THE FAN / LED WIRES ARE NOT TOUCHING THE HEATING ELEMENT
- 10.5 Replace the metal cover so that the water pan slots are at the correct end. Hold the cover in place and fit the 4 cap-head screws. Do not over-tighten.

10.6 In case of failure first check that the mains power supply is working and that the mains cable connector is fully engaged in the socket at the rear of the control housing. Check the fuse in the mains inlet on the rear of the control housing. Replace with a fuse of the same type and rating if necessary.

10.7 The digital control system may be reset to the original factory defaults by connecting the power supply while holding the OK button.

If the problem persists contact your distributor or Brinsea Products Service Dept.

10.8 The digital temperature display is calibrated during manufacture but may be re-calibrated if required. To ensure optimal performance return the brooder to Brinsea Products Service dept. for re-calibration every two years. It is not recommended that this procedure is carried out by the user.

BE CAUTIOUS OF LOW COST ANALOGUE OR DIGITAL THERMOMETERS.

BRINSEA PRODUCTS LTD USES SOPHISTICATED EQUIPMENT TRACEABLE TO INTERNATIONAL REFERENCE STANDARDS.







To access the Calibration Menu press all three buttons simultaneously to unlock the display. See page 12 for details of the Calibration Menu.

11 Specification

	TLC-40 Eco	TLC-50 Eco
Overall height	18.5" (470mm)	21.5" (550mm)
Overall width	19" (485mm)	27" (690mm)
Overall depth	15" (385mm)	19.5" (490mm)
Floor area	15.5 x 12" (400x300mm)	23.5 x 15.5" (600x400mm)
Effective volume	10USgal (40L)	26USgal (100L)
Weight	15lbs (6.7Kg)	19lbs (8.7Kg)
Power consumption	85W typical, 150W max	100W typical, 150W max
Power supply	115V 60Hz or 230V 50Hz as ordered	

Brinsea Products Inc., 704 N Dixie Ave., Titusville, FL 32796-2017 USA.
Phone. (321) 267-7009 Toll Free 1-888-667-7009 Fax (321) 267-6090
e-mail Sales@Brinsea.com, website www.Brinsea.com

CALIBRATION MENU

				PRESS ALL 3 BUTTONS TO UNLOCK THE CALIBRATION MENU
	SELECT THE OPTION / RETURN TO THE MENU.			
	GO FORWARD ONE SCREEN / INCREASE THE VALUE.			
	GO BACK ONE SCREEN / DECREASE THE VALUE.			

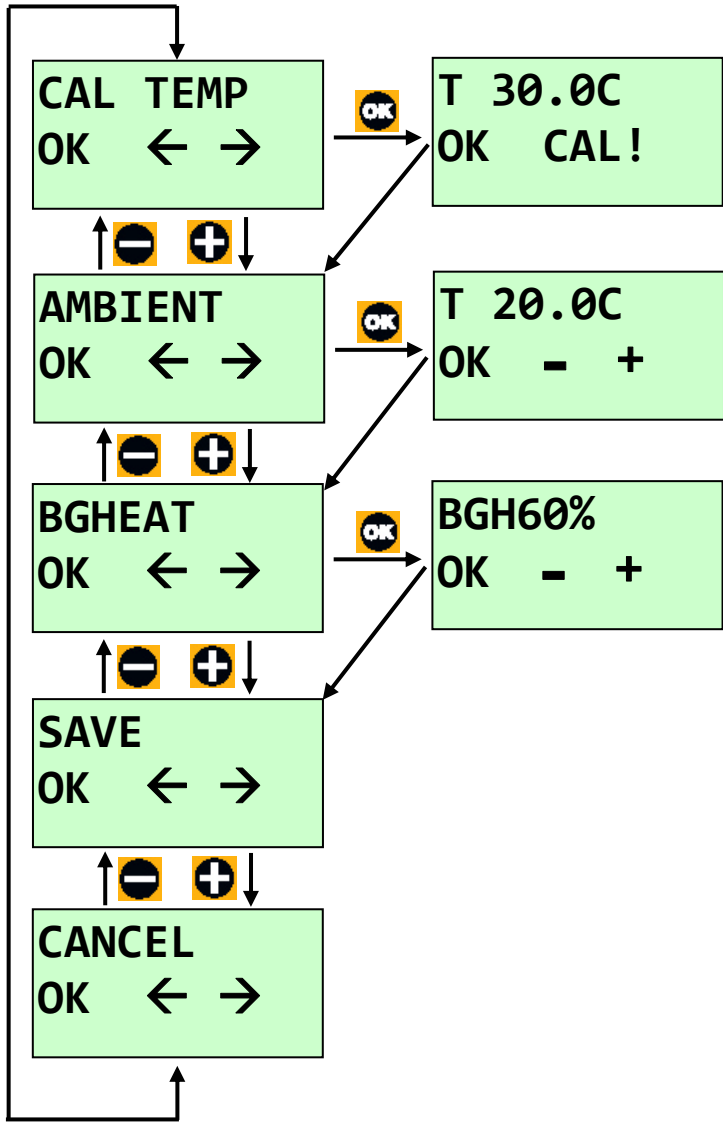

CALIBRATE THERMOMETER.
TAKE READINGS AT SEVERAL PLACES 1.5" (40mm) ABOVE THE BASE OF THE EMPTY BROODER AND CALCULATE THE AVERAGE.

AMBIENT TEMPERATURE COMPENSATION.
AMBIENT TEMPERATURE USED IN HEATER CONTROL ALGORITHM. ONLY ADJUST IF TYPICAL ROOM TEMPERATURE IS GREATER THAN 9°F (4°C) DIFFERENT.

BACKGROUND HEATING LEVEL.
HEATER POWER ADJUSTMENT USED IN HEATER CONTROL ALGORITHM. ONLY ADJUST WITH ADVICE FROM BRINSEA PRODUCTS.